

单向阀产品目录

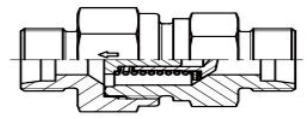

RD
p.167

管端24°内锥外螺纹/管端24°内锥外螺纹

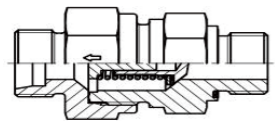

RV-R-WD
p.167

管端24°内锥外螺纹/柱端英制WD密封(ISO1179)

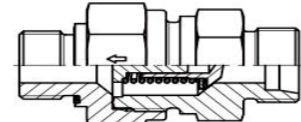

RZ-R-WD
p.168

柱端英制WD密封(ISO1179)/管端24°内锥外螺纹

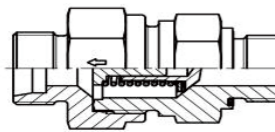

RV-M-WD
p.168

管端24°内锥外螺纹/柱端公制WD密封(ISO9974)

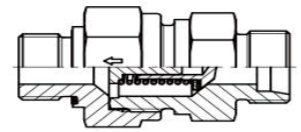

RZ-M-WD
p.169

柱端公制WD密封(ISO9974)/管端24°内锥外螺纹

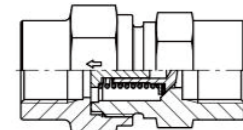

RDI-B
p.169

英制BSPP内螺纹/英制BSPP内螺纹

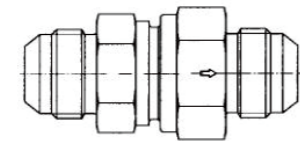

RDJ
p.169

管端37°美制JIC/管端37°美制JIC

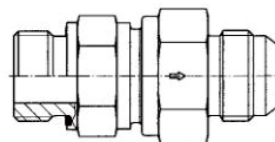

RVJ-R-WD
p.170

柱端英制WD密封(ISO1179)/管端37°美制JIC

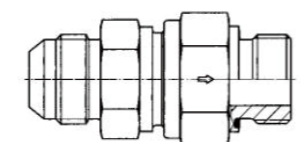

RZJ-R-WD
p.170

管端37°美制JIC/柱端英制WD密封(ISO1179)

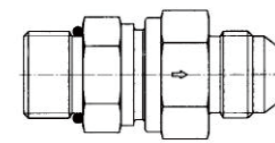

RVJ-UN
p.170

柱端美制O形圈密封(UN/UNF)/管端37°美制JIC

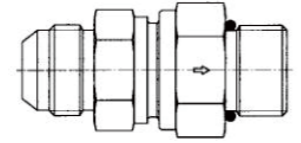

RZJ-UN
p.171

管端37°美制JIC/柱端美制O形圈密封(UN/UNF)

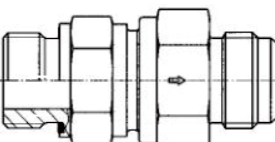

RVJ-M-WD
p.171

柱端公制WD密封(ISO9974)/管端37°美制JIC

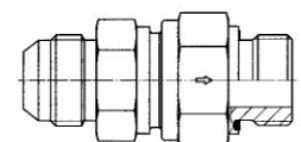

RZJ-M-WD
p.171

管端37°美制JIC/柱端公制WD密封(ISO9974)

单向阀产品目录

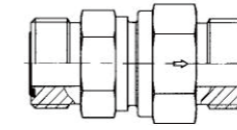

RDF
p.171

管端美制ORFS平面/管端美制ORFS平面

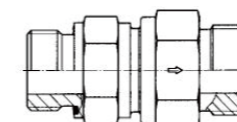

RVF-R-WD
p.172

柱端英制WD密封(ISO1179)/美制ORFS平面

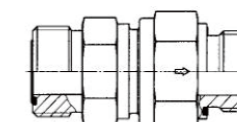

RZF-R-WD
p.172

美制ORFS平面/柱端英制WD密封(ISO1179)

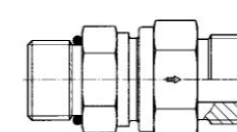

RVF-UN
p.172

柱端美制O形圈密封(UN/UNF)/美制ORFS平面

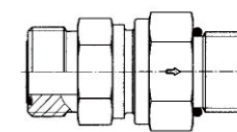

RZF-UN
p.172

美制ORFS平面/柱端美制O形圈密封(UN/UNF)

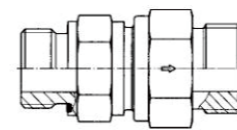

RVF-M-WD
p.173

柱端公制WD密封(ISO9974)/美制ORFS平面

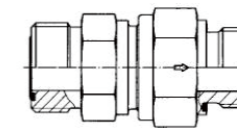

RZF-M-WD
p.173

美制ORFS平面/柱端公制WD密封(ISO9974)

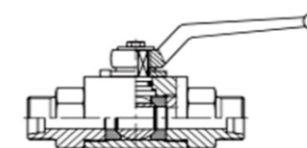

KHB-L
KHB-S
p.176

管端24°锥/管端24°锥

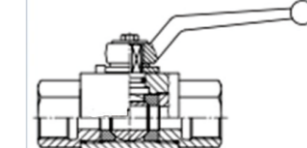

KHB-G
p.177

英制BSPP内螺纹/英制BSPP内螺纹

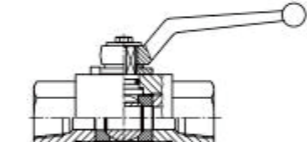

KHB-NPT
p.177

美制NPT内螺纹/美制NPT内螺纹

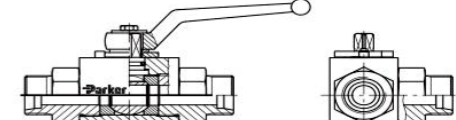

KHB3K-L p.176
KHB3K-S p.176

管端24°锥/管端24°锥/管端24°锥

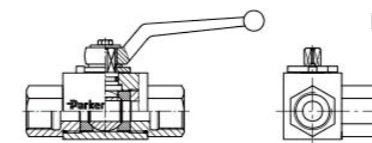

KHB3K-G
p.177

英制BSPP内螺纹/英制BSPP内螺纹/英制BSPP内螺纹

梭阀
Shuttlevalve

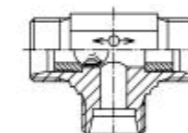

SF-AC
p.178

管端24°锥/管端24°锥/管端24°锥

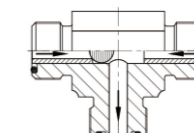

SF-AF
p.178

美制ORFS/美制ORFS/美制ORFS

RD/RV/RZ 单向阀技术说明

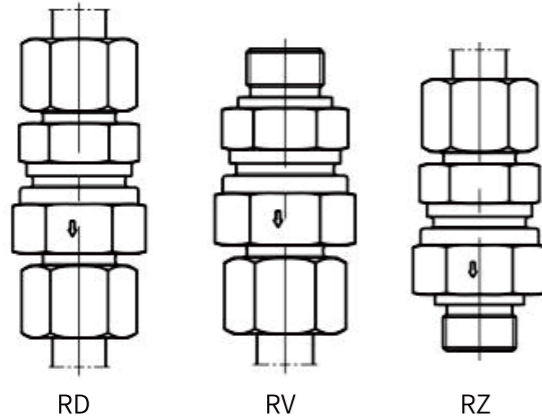
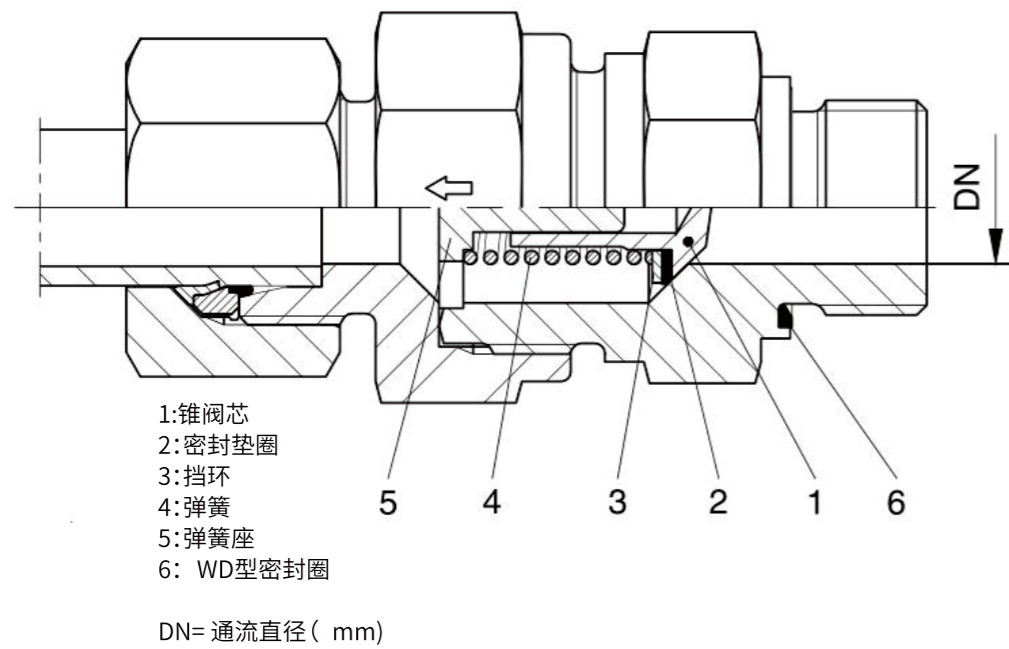

- 1:锥阀芯
2:密封垫圈
3:挡环
4:弹簧
5:弹簧座
6: WD型密封圈
- DN= 通流直径 (mm)

特性:

通过90°锥阀芯和合成材料的密封垫圈与锥阀座配合实现密封。阀芯开启具有定位, 因此开启可靠, 振动小, 噪音低, 阀体流通截面均匀。推荐最大流速不超过8米/秒

开启压力:

标准开启压力为1bar (如需开启压力0.2, 0.5, 2, 3, 4, 5, 6, bar, 可在订货时特别注明)。开启压力允许在±20%内变化。

材料:

无六价铬镀锌, 密封材料丁腈橡胶或者氟橡胶。不锈钢材料, 密封材料为氟橡胶 (采用不锈钢材质时, 在整个代号后加SS)

介质:

液压油。

RD/RV/RZ 单向阀技术说明

所有图表中允许的流量峰值为8米/米

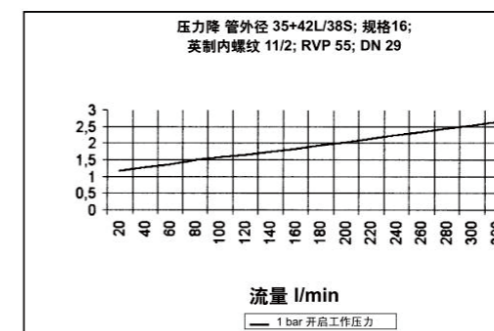
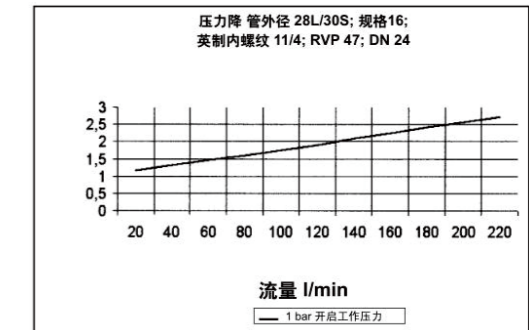
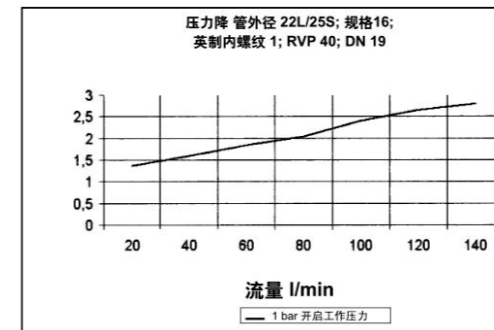
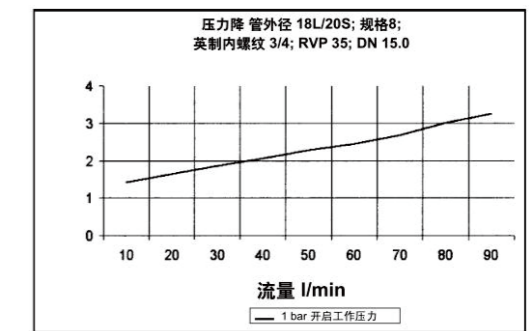
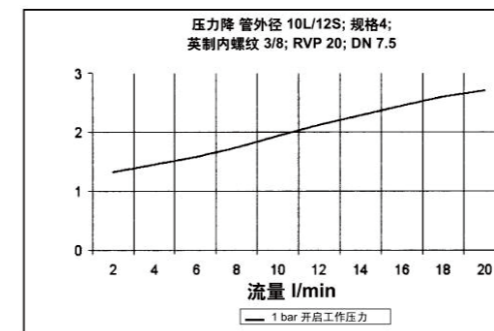
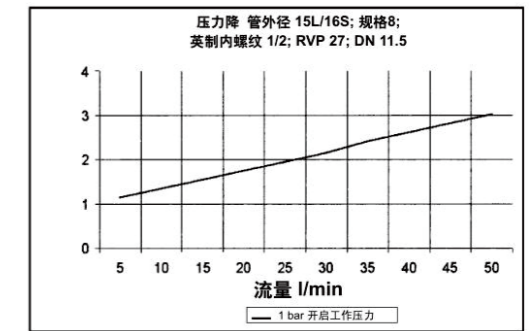
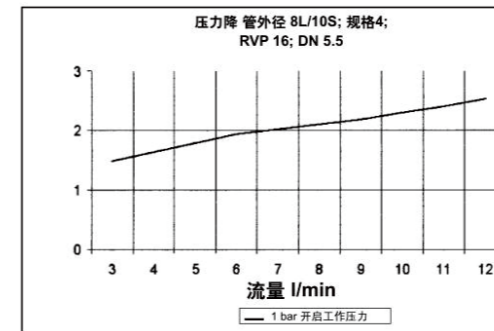
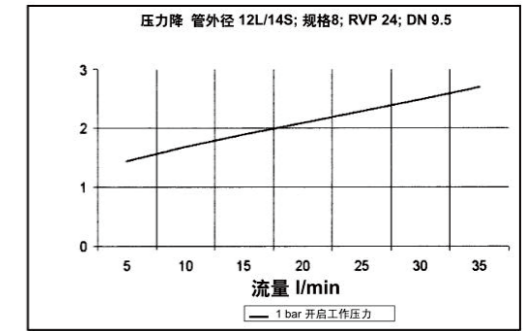
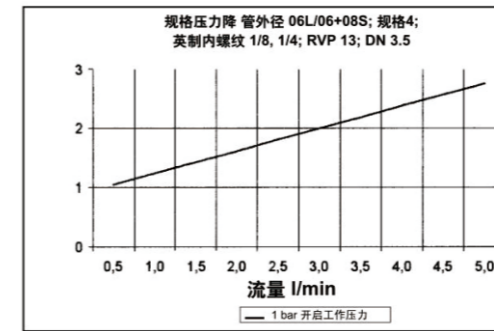

RD

管端24°内锥外螺纹/
管端24°内锥外螺纹

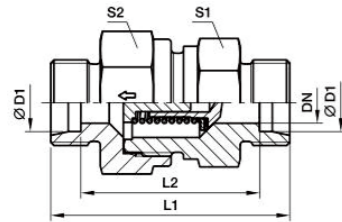

系列	产品代号 PART NO.	螺纹 THREAD		管子外径 TUBEO.D	尺寸 DIMENSIONS						重量 克/件	工作压力 (bar)		
		T	T1		碳钢 DN	不锈钢 DN	L1	L2	S1	碳钢 S2		不锈钢 S2	碳钢(CF)	不锈钢(SS)
L	RD-06L	M12X1.5		6	3.5	3.5	43.0	29.0	17	17	17	46	400	250
	RD-08L	M14X1.5		8	5.5	5.5	44.0	30.0	19	19	19	61	400	250
	RD-10L	M16X1.5		10	7.5	7.5	55.0	40.5	22	24	24	104	400	250
	RD-12L	M18X1.5		12	9.5	9.5	58.0	43.5	27	30	30	166	400	250
	RD-15L	M22X1.5		15	11.0	11.5	62.0	47.5	27	32	32	192	400	250
	RD-18L	M26X1.5		18	14.0	14.0	67.0	51.5	36	41	41	292	400	160
	RD-22L	M30X2.0		22	18.0	18.0	77.0	61.5	41	46	46	472	250	160
	RD-28L	M36X2.0		28	23.0	23.0	85.0	69.5	50	55	55	746	250	100
	RD-35L	M45X2.0		35	29.0	29.0	96.0	74.5	55	60	60	1062	250	100
	RD-42L	M52X2.0		42	29.0	29.0	96.0	74.0	65	70	70	1518	250	100
S	RD-06S	M14X1.5		6	3.5	3.5	48.5	34.5	19	19	19	70	420	400
	RD-08S	M16X1.5		8	3.5	3.5	48.5	34.5	19	19	19	74	420	400
	RD-10S	M18X1.5		10	5.5	5.5	55.5	40.5	22	24	24	121	420	400
	RD-12S	M20X1.5		12	7.5	7.5	57.5	42.5	24	27	27	148	420	400
	RD-14S	M22X1.5		14	9.5	9.5	64.0	47.5	27	32	32	218	420	315
	RD-16S	M24X1.5		16	11.0	11.5	68.0	50.5	32	36	36	286	420	315
	RD-20S	M30X2.0		20	15.0	15.0	76.0	54.5	41	50	46	506	420	250
	RD-25S	M36X2.0		25	19.0	19.0	83.0	58.5	50	55	50	639	420	250
	RD-30S	M42X2.0		30	24.0	24.0	97.0	69.5	55	60	60	1157	250	250
	RD-38S	M52X2.0		38	29.0	29.0	108.0	75.5	65	70	70	1650	250	250

RZ-R-WD

柱端英制WD密封(ISO1179)/
管端24°内锥外螺纹

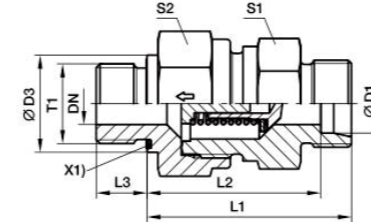

系列	产品代号 PART NO.	螺纹 THREAD		管子外径 TUBEO.D	尺寸 DIMENSIONS						重量 克/件	工作压力 (bar)		
		T	T1		DN	D3	L1	L2	L3	S1		S2	碳钢(CF)	不锈钢(SS)
L	RZ-06LRWD	M12X1.5	G1/8A	6	3.5	14	33.5	26.5	8	17	17	44	400	250
	RZ-08LRWD	M14X1.5	G1/4A	8	5.5	19	35.5	28.5	12	19	19	59	400	250
	RZ-10LRWD	M16X1.5	G1/4A	10	7.5	19	46.0	38.5	12	22	24	125	400	250
	RZ-12LRWD	M18X1.5	G3/8A	12	9.5	22	48.0	40.5	12	27	30	161	400	250
	RZ-15LRWD	M22X1.5	G1/2A	15	11.5	27	50.0	42.5	14	27	32	186	400	250
	RZ-18LRWD	M26X1.5	G1/2A	18	14.0	27	56.0	48.0	14	36	41	275	400	160
	RZ-22LRWD	M30X2.0	G3/4A	22	18.0	32	64.0	56.0	16	41	46	463	250	160
	RZ-28LRWD	M36X2.0	G1A	28	23.0	40	72.0	64.0	18	50	55	721	250	100
	RZ-35LRWD	M45X2.0	G1.1/4A	35	29.0	50	81.0	70.0	20	55	60	1073	250	100
	RZ-42LRWD	M52X2.0	G1.1/2A	42	29.0	55	82.0	70.5	22	65	70	1602	250	100
S	RZ-06SRWD	M14X1.5	G1/4A	6	3.5	19	38.5	31.5	12	19	19	71	420	400
	RZ-08SRWD	M16X1.5	G1/4A	8	3.5	19	38.5	31.5	12	19	19	74	420	400
	RZ-10SRWD	M18X1.5	G3/8A	10	5.5	22	45.5	38.0	12	22	24	128	420	400
	RZ-12SRWD	M20X1.5	G3/8A	12	7.5	22	48.5	41.0	12	24	27	152	420	400
	RZ-14SRWD	M22X1.5	G1/2A	14	9.5	27	52.0	43.5	14	27	32	223	420	315
	RZ-16SRWD	M24X1.5	G1/2A	16	11.5	27	55.0	46.0	14	32	36	275	420	315
	RZ-20SRWD	M30X2.0	G3/4A	20	15.0	32	61.0	50.0	16	41	50	490	420	250
	RZ-25SRWD	M36X2.0	G1A	25	19.0	40	67.0	54.5	18	50	55	647	420	250
	RZ-30SRWD	M42X2.0	G1.1/4A	30	24.0	50	78.0	64.0	20	55	60	1180	250	250
	RZ-38SRWD	M52X2.0	G1.1/2A	38	29.0	55	88.0	71.5	22	65	70	1670	250	250

RV-R-WD

管端24°内锥外螺纹/
柱端英制WD密封(ISO1179)

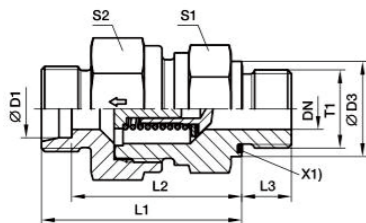

系列	产品代号 PART NO.	螺纹 THREAD		管子外径 TUBEO.D	尺寸 DIMENSIONS						重量 克/件	工作压力 (bar)		
		T	T1		DN	D3	L1	L2	L3	S1		S2	碳钢(CF)	不锈钢(SS)
L	RV-06LRWD	M12X1.5	G1/8A	6	3.5	14	35.0	28.0	8	17	17	47	400	250
	RV-08LRWD	M14X1.5	G1/4A	8	5.5	19	37.0	30.0	12	19	19	62	400	250
	RV-10LRWD	M16X1.5	G1/4A	10	7.5	19	46.0	38.5	12	22	24	105	400	250
	RV-12LRWD	M18X1.5	G3/8A	12	9.5	22	50.0	42.5	12	27	30	175	400	250
	RV-15LRWD	M22X1.5	G1/2A	15	11.5	27	53.0	45.5	14	27	32	205	400	250
	RV-18LRWD	M26X1.5	G1/2A	18	14.0	27	58.0	50.0	14	36	41	294	400	160
	RV-22LRWD	M30X2.0	G3/4A	22	18.0	32	63.0	55.0	16	41	46	450	250	160
	RV-28LRWD	M36X2.0	G1A	28	23.0	40	71.0	63.0	18	50	55	720	250	100
	RV-35LRWD	M45X2.0	G1.1/4A	35	29.0	50	80.0	69.0	20	55	60	1050	250	100
	RV-42LRWD	M52X2.0	G1.1/2A	42	29.0	55	80.0	68.5	22	65	70	1560	250	100
S	RV-06SRWD	M14X1.5	G1/4A	6	3.5	19	38.5	31.5	12	19	19	73	420	400
	RV-08SRWD	M16X1.5	G1/4A	8	3.5	19	38.5	31.5	12	19	19	79	420	400
	RV-10SRWD	M18X1.5	G3/8A	10	5.5	22	45.5	38.0	12	22	24	132	420	400
	RV-12SRWD	M20X1.5	G3/8A	12	7.5	22	48.5	41.0	12	24	27	153	420	400
	RV-14SRWD	M22X1.5	G1/2A	14	9.5	27	53.0	44.5	14	27	32	230	420	315
	RV-16SRWD	M24X1.5	G1/2A	16	11.5	27	57.0	48.0	14	32	36	293	420	315
	RV-20SRWD	M30X2.0	G3/4A	20	15.0	32	63.0	52.0	16	41	50	511	420	250
	RV-25SRWD	M36X2.0	G1A	25	19.0	40	66.5	54.5	18	46	55	648	420	250
	RV-30SRWD	M42X2.0	G1.1/4A	30	24.0	50	78	64.0	20	60	60	1176	250	250
	RV-38SRWD	M52X2.0	G1.1/2A	38	29.0	55	86	69.5	22	65	70	1624	250	250

RV-M-WD

管端24°内锥外螺纹/
柱端公制WD密封(ISO9974)

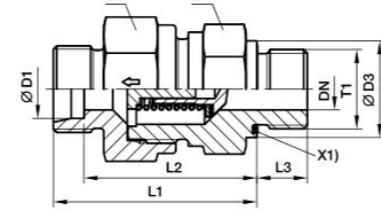

系列	产品代号 PART NO.	螺纹 THREAD		管子外径 TUBEO.D	尺寸 DIMENSIONS						重量 克/件	工作压力 (bar)		
		T	T1		DN	D3	L1	L2	L3	S1		S2	碳钢(CF)	不锈钢(SS)
L	RV-06LMWD	M12X1.5	M10X1.0	6	3.5	14	35.0	28.0	8	17	17	46	400	250
	RV-08LMWD	M14X1.5	M12X1.5	8	5.5	17	36.0	28.0	12	19	19	58	400	250
	RV-10LMWD	M16X1.5	M14X1.5	10	7.5	19	45.5	38.5	12	22	24	108	400	250
	RV-12LMWD	M18X1.5	M16X1.5	12	9.5	22	49.5	42.5	12	27	30	173	400	250
	RV-15LMWD	M22X1.5	M18X1.5	15	11.5	24	52.5	45.5	12	27	32	192	400	250
	RV-18LMWD	M26X1.5	M22X1.5	18	14.0	27	56.0	50.0	14	36	41	298	400	160
	RV-22LMWD	M30X2.0	M26X1.5	22	18.0	32	64.0	55.0	16	41	46	446	250	160
	RV-28LMWD	M36X2.0	M33X2.0	28	23.0	40	72.0	63.0	18	50	55	722	250	100
	RV-35LMWD	M45X2.0	M42X2.0	35	29.0	50	81.0	69.0	20	55	60	1053	250	100
	RV-42LMWD	M52X2.0	M48X2.0	42	29.0	55	82.0	68.5	22	65	70	1563	250	100
S	RV-06SMWD	M14X1.5	M12X1.5	6	3.5	17	38.5	31.5	12	19	19	70	420	400
	RV-08SMWD	M16X1.5	M14X1.5	8	3.5	19	38.5	31.5	12	19	19	76	420	400
	RV-10SMWD	M18X1.5	M16X1.5	10	5.5	22	45.5	38.0	12	22	24	124	420	400
	RV-12SMWD	M20X1.5	M18X1.5	12	7.5	24	48.5	41.0	12	24	27	157	420	400
	RV-14SMWD	M22X1.5	M20X1.5	14	9.5	26	52.5	44.5	14	27	32	215	420	315
	RV-16SMWD	M24X1.5	M22X1.5	16	11.5	27	55.0	48.0	14	32	36	296	420	315
	RV-20SMWD	M30X2.0	M27X2.0	20	15.0	32	61.0	52.0	16	41	50	521	420	250
	RV-25SMWD	M36X2.0	M33X2.0	25	19.0	40	67.0	54.5	18	46	55	648	420	250
	RV-30SMWD	M42X2.0	M42X2.0	30	24.0	50	78.0	64.0	20	60	60	1178	250	250
	RV-38SMWD	M52X2.0	M48X2.0	38	29.0	55	88.0	69.5	22	65	70	1627	250	250

RZ-M-WD

柱端公制WD密封(ISO9974)/
管端24°内锥外螺纹

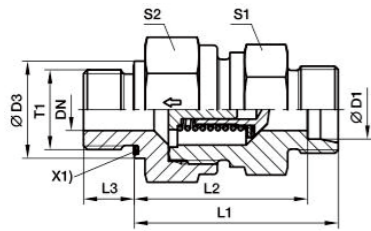

系列	产品代号 PART NO.	螺纹THREAD		管子外径 TUBE O.D	尺寸 DIMENSIONS								重量 克/件	工作压力 (bar)	
		T	T1		DN	DN	L1	L2	L3	S1	S2	碳钢 (CF)		不锈钢 (SS)	
L	RZ-06LMWD	M12X1.5	M10X1.0	6	3.5	3.5	33.5	26.5	8	17	17	44	400	250	
	RZ-08LMWD	M14X1.5	M12X1.5	8	5.5	5.5	35.5	28.5	12	19	19	58	400	250	
	RZ-10LMWD	M16X1.5	M14X1.5	10	7.5	7.5	45.5	38.5	12	22	24	104	400	250	
	RZ-12LMWD	M18X1.5	M16X1.5	12	9.5	9.5	47.5	40.5	12	27	30	169	400	250	
	RZ-15LMWD	M22X1.5	M18X1.5	15	11.5	11.5	49.5	42.5	12	27	32	174	400	250	
	RZ-18LMWD	M26X1.5	M22X1.5	18	14.0	14.0	55.5	48.0	14	36	41	279	400	160	
	RZ-22LMWD	M30X2.0	M26X1.5	22	18.0	18.0	63.5	56.0	16	41	46	459	250	160	
	RZ-28LMWD	M36X2.0	M33X2.0	28	23.0	23.0	71.5	64.0	18	50	55	721	250	100	
	RZ-35LMWD	M45X2.0	M42X2.0	35	29.0	29.0	80.5	70.0	20	55	60	1078	250	100	
	RZ-42LMWD	M52X2.0	M48X2.0	42	29.0	29.0	81.5	70.5	22	65	70	1601	250	100	
S	RZ-06SMWD	M14X1.5	M12X1.5	6	3.5	3.5	38.5	31.5	12	19	19	70	420	400	
	RZ-08SMWD	M16X1.5	M14X1.5	8	3.5	3.5	38.5	31.5	12	19	19	75	420	400	
	RZ-10SMWD	M18X1.5	M16X1.5	10	5.5	5.5	45.5	38.0	12	22	24	123	420	400	
	RZ-12SMWD	M20X1.5	M18X1.5	12	7.5	7.5	48.5	41.0	12	24	27	157	420	400	
	RZ-14SMWD	M22X1.5	M20X1.5	14	9.5	9.5	51.5	43.5	14	27	32	214	420	315	
	RZ-16SMWD	M24X1.5	M22X1.5	16	11.5	11.5	54.5	46.0	14	32	36	279	420	315	
	RZ-20SMWD	M30X2.0	M27X2.0	20	15.0	15.0	60.5	50.0	16	41	50	487	420	250	
	RZ-25SMWD	M36X2.0	M33X2.0	25	19.0	19.0	68.0	54.5	18	50	55	647	420	250	
	RZ-30SMWD	M42X2.0	M42X2.0	30	24.0	24.0	77.5	64.0	20	55	60	1180	250	250	
	RZ-38SMWD	M52X2.0	M48X2.0	38	29.0	29.0	87.5	71.5	22	65	70	1669	250	250	

RDI-B

英制BSP内螺纹/
英制BSP内螺纹

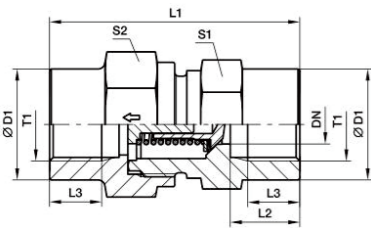

产品代号 PART NO.	螺纹THREAD	尺寸 DIMENSIONS								重量 克/件	工作压力 (bar)	
		T1	DN	D1	L1	L2	L3	S1	S2		碳钢 (CF)	不锈钢 (SS)
RDI-B02	G1/8A	3.5	19	42.5	12.0	8.0	19	19	76	400	400	
RDI-B04	G1/4A	3.5	19	51.0	16.0	12.0	19	19	82	400	400	
RDI-B06	G3/8A	7.5	24	60.0	17.0	12.0	24	27	157	400	400	
RDI-B08	G1/2A	11.5	32	72.0	20.0	15.0	32	36	344	315	315	
RDI-B12	G3/4A	15.0	41	84.0	22.0	16.5	41	46	664	250	250	
RDI-B16	G1A	19.0	46	95.0	25.5	19.0	46	50	821	250	250	
RDI-B20	G1.1/4A	24.0	60	110.0	28.0	21.5	60	60	1581	250	250	
RDI-B24	G1.1/2A	29.0	65	114.0	28.5	22.0	65	70	1919	250	250	

RDJ

管端37°美制JIC /
管端37°美制JIC

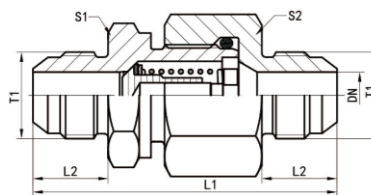

产品代号 PART NO.	螺纹THREAD	尺寸 DIMENSIONS								重量 克/件	工作压力 (bar)	
		T1	碳钢 DN	不锈钢 DN	L1	L2	S1	碳钢 S2	不锈钢 S2		碳钢 (CF)	不锈钢 (SS)
RDJ-04	7/16" -20UNF	3.5	3.5	51.0	14	17	17	17	51	400	250	
RDJ-05	1/2" -20UNF	3.5	3.5	52.0	14	17	17	17	60	400	250	
RDJ-06	9/16" -18UNF	7.5	7.5	61.2	14.1	19	19	19	116	400	250	
RDJ-08	3/4" -16UN	10.0	10.0	71.4	16.7	27	30	30	182	400	250	
RDJ-10	7/8" -14UN	12.0	12.0	81.6	19.3	27	32	32	214	400	250	
RDJ-12	1.1/16" -12UN	15.0	15.0	92.8	21.9	36	41	41	317	400	160	
RDJ-16	1.5/16" -12UN	21.5	21.5	103.2	23.1	50	55	55	502	250	160	
RDJ-20	1.5/8" -12UN	27.5	27.5	112.6	24.3	60	65	65	781	250	100	
RDJ-24	1.7/8" -12UN	29.0	29.0	119.0	27.5	65	70	70	1107	210	100	

RVJ-R-WD

柱端英制WD密封(ISO1179)/
管端37°美制JIC

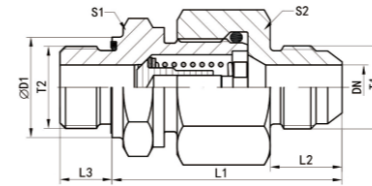

产品代号 PART NO.	螺纹THREAD		尺寸 DIMENSIONS								重量 克/件	工作压力 (bar)	
	T1	T2	DN	D1	L1	L2	L3	S1	S2	碳钢 (CF)		不锈钢 (SS)	
RVJ-04RWD	7/16"20UNF	G1/8A	3.5	14	41	14	8	17	17	50	400	250	
RVJ-05RWD	1/2"-20UNF	G1/8A	3.5	14	43	14	8	17	17	64	400	250	
RVJ-06RWD	9/16"-18UNF	G1/4A	7.5	19	51.6	14.1	12	19	19	115	400	250	
RVJ-08RWD	3/4"-16UN	G3/8A	10.0	22	60.7	16.7	12	27	30	217	400	250	
RVJ-10RWD	7/8"-14UN	G1/2A	12.0	27	68.3	19.3	14	27	32	316	400	160	
RVJ-12RWD	1.1/16"12UN	G3/4A	15.0	32	73.9	21.9	16	41	41	468	250	160	
RVJ-16RWD	1.5/16"12UN	G1A	21.5	40	83.1	23.1	18	50	55	739	250	100	
RVJ-20RWD	1.5/8"12UN	G1.1/4A	27.5	50	91.8	24.3	20	60	65	1090	250	100	
RVJ-24RWD	1.7/8"12UN	G1.1/2A	29.0	55	95	27.5	22	65	70	1596	250	100	

RZJ-R-WD

管端37°美制JIC/
柱端英制WD密封(ISO1179)

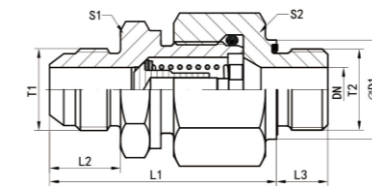

产品代号 PART NO.	螺纹THREAD		尺寸 DIMENSIONS								重量 克/件	工作压力 (bar)	
	T1	T2	DN	D1	L1	L2	L3	S1	S2	碳钢 (CF)		不锈钢 (SS)	
RZJ-04RWD	7/16"20UNF	G1/8A	3.5	14	39.5	14	8	17	17	49	400	250	
RZJ-05RWD	1/2"-20UNF	G1/8A	3.5	14	41.5	14	8	17	17	65	400	250	
RZJ-06RWD	9/16"18UNF	G1/4A	7.5	19	51.6	14.1	12	19	19	137	400	250	
RZJ-08RWD	3/4"-16UN	G3/8A	10.0	22	55.7	16.7	12	27	30	177	400	250	
RZJ-10RWD	7/8"-14UN	G1/2A	12.0	27	60.3	19.3	14	27	32	208	400	160	
RZJ-12RWD	1.1/16"12UN	G3/4A	15.0	32	66.9	21.9	16	36	41	300	250	160	
RZJ-16RWD	1.5/16"12UN	G1A	21.5	40	84.1	23.1	18	50	55	751	250	100	
RZJ-20RWD	1.5/8"12UN	G1.1/4A	27.5	50	92.8	24.3	20	60	65	1108	250	100	
RZJ-24RWD	1.7/8"12UN	G1.1/2A	29.0	55	97.0	27.5	22	65	70	1647	250	100	

RVJ-UN

柱端美制O形圈密封(UN/UNF)/
管端37°美制JIC

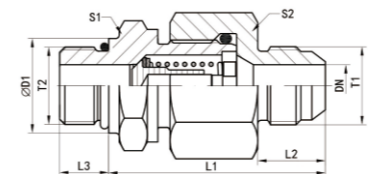

产品代号 PART NO.	螺纹THREAD		尺寸 DIMENSIONS								重量 克/件	工作压力 (bar)	
	T1	T2	DN	D1	L1	L2	L3	S1	S2	碳钢 (CF)		不锈钢 (SS)	
RVJ-04UN	7/16"20UNF	7/16"20UNF	3.5	17	48.0	14	9	17	17	50	400	250	
RVJ-05UN	1/2"-20UNF	1/2"-20UNF	3.5	17	49.0	14	9	17	17	64	400	250	
RVJ-06UN	9/16"18UNF	9/16"18UNF	7.5	19	59.6	14.1	10	19	19	115	400	250	
RVJ-08UN	3/4"-16UN	3/4"-16UN	10.0	24	68.7	16.7	11	27	30	217	400	250	
RVJ-10UN	7/8"-14UN	7/8"-14UN	12.0	27	78.0	19.3	12.7	27	32	316	400	160	
RVJ-12UN	1.1/16"12UN	1.1/16"12UN	15.0	32	88.9	21.9	15	36	41	468	250	160	
RVJ-16UN	1.5/16"12UN	1.5/16"12UN	21.5	40	98.1	23.1	15	50	55	739	250	100	
RVJ-20UN	1.5/8"12UN	1.5/8"12UN	27.5	50	106.8	24.3	15	60	65	1090	250	100	
RVJ-24UN	1.7/8"12UN	1.7/8"12UN	29.0	55	110.0	27.5	15	65	70	1596	250	100	

RZJ-UN

管端37°美制JIC/
柱端美制O形圈密封(UN/UNF)

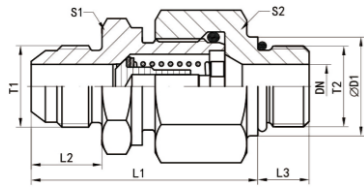

产品代号 PART NO.	螺纹THREAD		尺寸 DIMENSIONS								重量 克/件	工作压力 (bar)	
	T1	T2	DN	D1	L1	L2	L3	S1	S2	碳钢 (CF)		不锈钢 (SS)	
RZJ-04UN	7/16"-20UNF	7/16"20UNF	3.5	17	48.0	14	9	17	17	49	400	250	
RZJ-05UN	1/2"-20UNF	1/2"-20UNF	3.5	17	49.0	14	9	17	17	65	400	250	
RZJ-06UN	9/16"-18UNF	9/16"-18UNF	7.5	19	59.6	14.1	10	19	19	137	400	250	
RZJ-08UN	3/4"-16UN	3/4"-16UN	10.0	24	68.7	16.7	11	27	30	177	400	250	
RZJ-10UN	7/8"-14UN	7/8"-14UN	12.0	27	78.0	19.3	12.7	27	32	208	400	160	
RZJ-12UN	1.1/16"-12UN	1.1/16"-12UN	15.0	32	88.9	21.9	15	36	41	300	250	160	
RZJ-16UN	1.5/16"-12UN	1.5/16"-12UN	21.5	40	98.1	23.1	15	50	55	751	250	100	
RZJ-20UN	1.5/8"-12UN	1.5/8"-12UN	27.5	50	106.8	24.3	15	60	65	1108	250	100	
RZJ-24UN	1.7/8"-12UN	1.7/8"-12UN	29.0	55	110.0	27.5	15	65	70	1647	250	100	

RVJ-M-WD

柱端公制WD密封(ISO9974)/
管端37°美制JIC

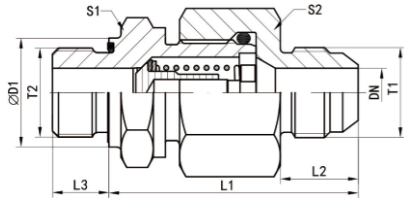

产品代号 PART NO.	螺纹THREAD		尺寸 DIMENSIONS								重量 克/件	工作压力 (bar)	
	T1	T2	DN	D1	L1	L2	L3	S1	S2	碳钢 (CF)		不锈钢 (SS)	
RVJ-04MWD	7/16"-20UNF	M10X1.0	3.5	14	41.0	14	8	17	17	50	400	250	
RVJ-05MWD	1/2"-20UNF	M12X1.5	3.5	17	47.0	14	12	17	17	64	400	250	
RVJ-06MWD	9/16"-18UNF	M14X1.5	7.5	19	51.6	14.1	12	19	19	115	400	250	
RVJ-08MWD	3/4"-16UN	M16X1.5	10.0	22	60.7	16.7	12	27	30	217	400	250	
RVJ-10MWD	7/8"-14UN	M22X1.5	12.0	27	68.3	19.3	14	27	32	316	400	160	
RVJ-12MWD	1.1/16"-12UN	M27X2.0	15.0	32	73.9	21.9	16	41	41	468	250	160	
RVJ-16MWD	1.5/16"-12UN	M33X2.0	21.5	40	83.1	23.1	18	50	55	739	250	100	
RVJ-20MWD	1.5/8"-12UN	M42X2.0	27.5	50	91.8	24.3	20	60	65	1090	250	100	
RVJ-24MWD	1.7/8"-12UN	M48X2.0	29.0	55	95.0	27.5	22	65	70	1596	250	100	

RZJ-M-WD

管端37°美制JIC/
柱端公制WD密封(ISO9974)

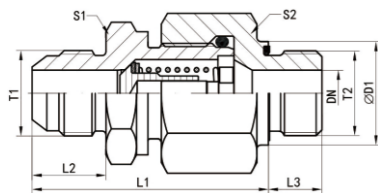

产品代号 PART NO.	螺纹THREAD		尺寸 DIMENSIONS								重量 克/件	工作压力 (bar)	
	T1	T2	DN	D1	L1	L2	L3	S1	S2	碳钢 (CF)		不锈钢 (SS)	
RZJ-04MWD	7/16"-20UNF	M10X1.0	3.5	14	39.5	14	8	17	17	49	400	250	
RZJ-05MWD	1/2"-20UNF	M12X1.5	3.5	14	45.5	14	12	17	17	65	400	250	
RZJ-06MWD	9/16"-18UNF	M14X1.5	7.5	19	51.6	14.1	12	19	19	137	400	250	
RZJ-08MWD	3/4"-16UN	M16X1.5	10.0	22	55.7	16.7	12	27	30	177	400	250	
RZJ-10MWD	7/8"-14UN	M22X1.5	12.0	27	60.3	19.3	14	27	32	208	400	160	
RZJ-12MWD	1.1/16"-12UN	M27X2.0	15.0	32	66.9	21.9	16	36	41	300	250	160	
RZJ-16MWD	1.5/16"-12UN	M33X2.0	21.5	40	84.1	23.1	18	50	55	751	250	100	
RZJ-20MWD	1.5/8"-12UN	M42X2.0	27.5	50	92.8	24.3	20	60	65	1108	250	100	
RZJ-24MWD	1.7/8"-12UN	M48X2.0	29.0	55	97.0	27.5	22	65	70	1647	250	100	

RDF

管端美制ORFS平面/
管端美制ORFS平面

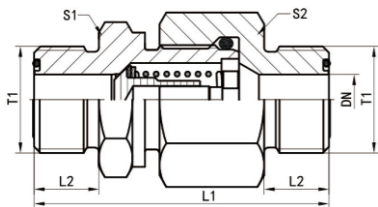

产品代号 PART NO.	螺纹THREAD		尺寸 DIMENSIONS								重量 克/件	工作压力 (bar)	
	T1	碳钢 DN	不锈钢 DN	L1	L2	S1	碳钢 S2	不锈钢 S2	碳钢 (CF)	不锈钢 (SS)			
RDF-04	9/16"-18UNF	3.5	3.5	43	10	19	19	19	51	400	250		
RDF-06	11/16"-16UN	6.5	6.5	55	11	22	24	24	116	400	250		
RDF-08	13/16"-16UN	9.5	9.5	64	13	24	27	27	182	400	250		
RDF-10	1"-14UNS	12.0	12.0	74	15.5	32	36	36	214	400	250		
RDF-12	1.3/16"-12UN	15.0	15.0	83	17	41	50	50	317	400	160		
RDF-16	1.7/16"-12UN	20.5	20.5	92	17.5	50	55	55	502	250	160		
RDF-20	1.11/16"-12UN	26.0	26.0	99	17.5	55	60	60	781	250	100		
RDF-24	2"-12UN	29.0	29.0	99	17.5	65	70	70	1107	210	100		

RVF-R-WD

柱端英制WD密封(ISO1179)/
美制ORFS平面

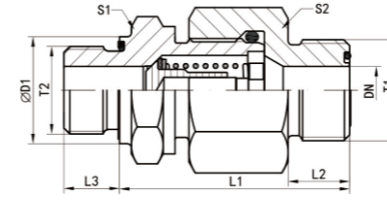

产品代号 PART NO.	螺纹THREAD		尺寸 DIMENSIONS								重量 克/件	工作压力 (bar)	
	T1	T2	DN	D1	L1	L2	L3	S1	S2	碳钢 (CF)		不锈钢 (SS)	
RVF-04RWD	9/16"-18UNF	G1/8A	3.5	14	37.0	10	8	17	19	50	400	250	
RVF-06RWD	11/16"-16UN	G1/4A	6.5	19	48.5	11	12	19	24	115	400	250	
RVF-08RWD	13/16"-16UN	G3/8A	9.5	22	57.0	13	12	27	27	217	400	250	
RVF-10RWD	1"-14UNS	G1/2A	12.0	27	64.5	15.5	14	32	36	316	400	160	
RVF-12RWD	1.3/16"-12UN	G3/4A	15.0	32	69.0	17	16	41	50	468	250	160	
RVF-16RWD	1.7/16"-12UN	G1A	20.5	40	77.5	17.5	18	50	55	739	250	100	
RVF-20RWD	1.11/16"-12UN	G1.1/4A	26.0	50	85.0	17.5	20	60	60	1090	250	100	
RVF-24RWD	2"-12UN	G1.1/2A	29.0	55	85.0	17.5	22	65	70	1596	250	100	

RZF-R-WD

美制ORFS平面/
柱端英制WD密封(ISO1179)

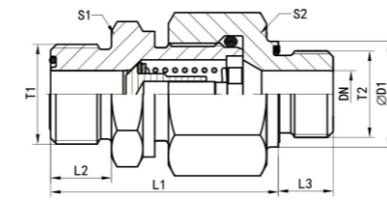

产品代号 PART NO.	螺纹THREAD		尺寸 DIMENSIONS								重量 克/件	工作压力 (bar)	
	T1	T2	DN	D1	L1	L2	L3	S1	S2	碳钢 (CF)		不锈钢 (SS)	
RZF-04RWD	9/16"-18UNF	G1/8A	3.5	14	35.5	10	8	17	17	49	400	250	
RZF-06RWD	11/16"-16UN	G1/4A	6.5	19	48.5	11	12	22	24	137	400	250	
RZF-08RWD	13/16"-16UN	G3/8A	9.5	22	52.0	13	12	24	27	177	400	250	
RZF-10RWD	1"-14UNS	G1/2A	12.0	27	56.5	15.5	14	32	36	208	400	160	
RZF-12RWD	1.3/16"-12UN	G3/4A	15.0	32	62.0	17	16	41	50	300	250	160	
RZF-16RWD	1.7/16"-12UN	G1A	20.5	40	78.5	17.5	18	50	55	751	250	100	
RZF-20RWD	1.11/16"-12UN	G1.1/4A	26.0	50	86.0	17.5	20	55	60	1108	250	100	
RZF-24RWD	2"-12UN	G1.1/2A	29.0	55	87.0	17.5	22	65	70	1647	250	100	

RVF-UN

柱端美制O形圈密封(UN/UNF)/
美制ORFS平面

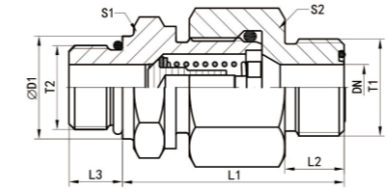

产品代号 PART NO.	螺纹 THREAD		尺寸 DIMENSIONS								重量 克/件	工作压力 (bar)	
	T1	T2	DN	D1	L1	L2	L3	S1	S2	碳钢 (CF)		不锈钢 (SS)	
RVF-04UN	9/16"-18UNF	7/16"-20UNF	3.5	17	44.0	10	9	17	19	50	400	250	
RVF-06UN	11/16"-16UN	9/16"-18UNF	6.5	19	56.5	11	10	19	24	115	400	250	
RVF-08UN	13/16"-16UN	3/4"-16UN	9.5	24	65.0	13	11	24	27	217	400	250	
RVF-10UN	1"-14UNS	7/8"-14UN	12.0	27	74.2	15.5	12.7	32	36	316	400	160	
RVF-12UN	1.3/16"-12UN	1.1/16"-12UN	15.0	32	84.0	17	15	41	50	468	250	160	
RVF-16UN	1.7/16"-12UN	1.5/16"-12UN	20.5	40	92.5	17.5	15	50	55	739	250	100	
RVF-20UN	1.11/16"-12UN	1.5/8"-12UN	26.0	50	100.0	17.5	15	60	60	1090	250	100	
RVF-24UN	2"-12UN	1.7/8"-12UN	29.0	55	100.0	17.5	15	65	70	1596	250	100	

RZF-UN

美制ORFS平面/
柱端美制O形圈密封(UN/UNF)

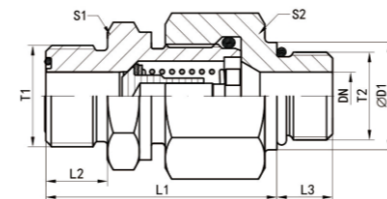

产品代号 PART NO.	螺纹THREAD		尺寸 DIMENSIONS								重量 克/件	工作压力 (bar)	
	T1	T2	DN	D1	L1	L2	L3	S1	S2	碳钢 (CF)		不锈钢 (SS)	
RZF-04UN	9/16"-18UNF	7/16"-20UNF	3.5	17	44	10	9	19	19	49	400	250	
RZF-06UN	11/16"-16UN	9/16"-18UNF	6.5	19	56.5	11	10	22	24	137	400	250	
RZF-08UN	13/16"-16UN	3/4"-16UN	9.5	24	65	13	11	24	27	177	400	250	
RZF-10UN	1"-14UNS	7/8"-14UN	12.0	27	74.2	15.5	12.7	32	36	208	400	160	
RZF-12UN	1.3/16"-12UN	1.1/16"-12UN	15.0	32	84	17	15	41	50	300	250	160	
RZF-16UN	1.7/16"-12UN	1.5/16"-12UN	20.5	40	92.5	17.5	15	50	55	751	250	100	
RZF-20UN	1.11/16"-12UN	1.5/8"-12UN	26.0	50	100	17.5	15	55	60	1108	250	100	
RZF-24UN	2"-12UN	1.7/8"-12UN	29.0	55	100	17.5	15	65	70	1647	250	100	

RVF-M-WD

柱端公制WD密封(ISO9974)/
美制ORFS平面

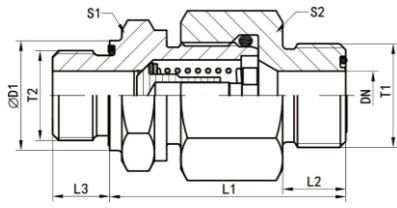

产品代号 PART NO.	螺纹 THREAD		尺寸 DIMENSIONS							重量 克/件	工作压力 (bar)	
	T1	T2	DN	D1	L1	L2	L3	S1	S2		碳钢(CF)	不锈钢(SS)
RVF-04MWD	9/16"18UNF	M12X1.5	3.5	14	37.0	10	8	17	19	50	400	250
RVF-06MWD	11/16"16UN	M14X1.5	6.5	19	48.5	11	12	22	24	115	400	250
RVF-08MWD	13/16"16UN	M16X1.5	9.5	22	57.0	13	12	22	27	217	400	250
RVF-10MWD	1" -14UNS	M22X1.5	12.0	27	64.5	15.5	14	32	36	316	400	160
RVF-12MWD	1.3/16"12UN	M27X2.0	15.0	32	69.0	17	16	41	50	468	250	160
RVF-16MWD	1.7/16"12UN	M33X2.0	20.5	40	77.5	17.5	18	50	55	739	250	100
RVF-20MWD	1.11/16"12UN	M42X2.0	26.0	50	85.0	17.5	20	55	60	1090	250	100
RVF-24MWD	2" -12UN	M48X2.0	29.0	55	85.0	17.5	22	65	70	1596	250	100

RZF-M-WD

美制ORFS平面/
柱端公制WD密封(ISO9974)

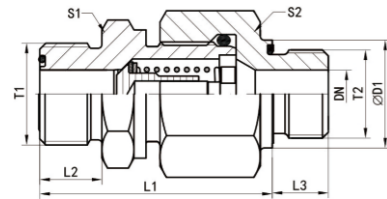

产品代号 PART NO.	螺纹 THREAD		尺寸 DIMENSIONS							重量 克/件	工作压力 (bar)	
	T1	T2	DN	D1	L1	L2	L3	S1	S2		碳钢(CF)	不锈钢(SS)
RZF-04MWD	9/16"18UNF	M12X1.5	3.5	14	35.5	10	8	19	19	49	400	250
RZF-06MWD	11/16"16UN	M14X1.5	6.5	19	48.5	11	12	22	24	137	400	250
RZF-08MWD	13/16"16UN	M16X1.5	9.5	22	52.0	13	12	24	30	177	400	250
RZF-10MWD	1" -14UNS	M22X1.5	12.0	27	56.5	15.5	14	32	36	208	400	160
RZF-12MWD	1.3/16"12UN	M27X2.0	15.0	32	62.0	17	16	41	50	300	250	160
RZF-16MWD	1.7/16"12UN	M33X2.0	20.5	40	78.5	17.5	18	50	55	751	250	100
RZF-20MWD	1.11/16"12UN	M42X2.0	26.0	50	86.0	17.5	20	55	60	1108	250	100
RZF-24MWD	2" -12UN	M48X2.0	29.0	55	87.0	17.5	22	65	70	1647	250	100

球阀及截止阀的说明与操作手册

1、一般性参考

球阀用于关断钢管及软管中的带压力介质。宁波怡盛液压设计制造的球阀可以安全使用;但是不正确的使用或违反安全操作时,球阀将变成一个危险源。

根据客户告知的使用介质、压力、温度等参数,宁波怡盛液压将选择合适的阀体材料、球座、密封件等。使用采购订单中所注明流通介质以外的介质时会降低球阀使用寿命或产生故障。客户在使用球阀时,应严格按球阀最大工作压力和适用温度范围内适用,在选用球阀时,必须将使用的工作压力(包括峰值压力或脉冲压力)考虑进去,以免球阀过早失效。

球阀可以安装在同等压力等级的接头和法兰的管路系统中,通过旋转球阀手柄的动作来打开或关闭球阀,根据EN ISO 5211.8的要求,手柄顺时针转动为关闭球阀,方形轴上的凹口可能显示球阀当前位置,可以通过手柄或执行器来操作球阀,在订购球阀时需注明球阀的操作方式。

2、接头指导

在球阀安装前,需核对球阀是否满足所有关于类型和应用方面必备的条件。只能让有资质的人员在管路和球阀卸压后进行球阀的安装。在保证没有残余应力的情况下将钢管连接到球阀。在收到货物后和安装前,必须先检查球阀是否因运输或其它原因造成损坏,如有损坏应在第一时间通知宁波怡盛液压品管部;损坏的球阀不能继续使用。

在球阀安装前,所有的钢管和软管必须冲洗干净。管路系统中的残余杂质会损坏球阀的密封件导致球阀发生泄漏而使其失效。当拧紧接头时,必须使用合适的工具来旋紧球阀端部的接头;球阀上的接头,出厂前已按相应力矩拧紧,请不要增大扭矩进行再次拧紧或松开,这样会增大拆卸的扭矩或者导致泄漏。在球阀安装好后,必须做功能性测试,球阀的零件如接头、顶部法兰不能被取走或拧下。当使用有害的、易燃的、爆炸性的介质时,必须把球阀和管路系统中的液体全部排除干净;操作时必须穿戴适合的防护服进行。

3、初始操作

在初始操作前,必须阅读所有操作说明书,必须确认球阀操作和安装的所有工况(安装的初始操作只能让有资质的人员来完成)。

球阀经过长时间的存放和处于关闭状态下,第一次的操作扭矩相比常规的扭矩会明显增大,这属于正常现象。在第一次操作前,必须排空管路系统内的空气,当压力迅速提升时,管路中的气泡会引起爆炸,因此需要合理的施加系统压力。当球阀安装到管路系统时,打开的接头必须正确的关闭,因不正确的操作或元件损坏都可能会导致严重的故障甚至造成人员伤亡事故。

4、更换指导

当球阀和管路系统在卸压后,球阀的更换必须且只能让有资质的人员来完成。在拆卸球阀前,管路系统中的压力必须被释放掉,球阀必须位于中间45°位置来释放腔体内的压力。当使用有害、易燃、爆炸性的介质时,必须把球阀和管路系统中的残余液体全部排干净,并穿戴适合的防护服进行操作。

特别说明:

1. 球阀必须在规定的的应用范围内使用;
2. 无资质的人员使用不正确的安装和操作导致的损坏,宁波怡盛液压将不承担任何责任。
3. 球阀的操作位置必须严格执行完全打开或完全关闭两种状态,球阀不能用于流量控制,中间操作位置会导致球座的损坏从而引起球阀泄漏或轴不能转动。流量的减少会导致球阀表面温度的迅速上升。
4. 使用正确的工具(如钳子、榔头、扳钳、加长扳手等不适合球阀的安装)进行安装,否则会导致转动轴和阀体的损坏。
5. 对于特殊应用或者恶劣的工况(潮湿、震动、频繁的操作、磁性的场合、爆炸性区域、抗静电等)请在订购时清晰注明!
6. 球阀只能用于规定范围内的介质。禁止使用半固态或者固态的介质。必须避免污染,受污染的介质会损坏密封件,进而会导致球阀的泄漏和损坏。
7. 不能超出规定的极限温度范围,否则球阀会过早失效,球阀的存储必须保持干燥、没有污染,只有在安装前,才能去除保护盖;未拆封的球阀必须避免受紫外线和阳光的照射。
8. 当球阀安装在爆炸性区域时,操作的频率应该小于每分钟10次,防止球阀自身温度的上升。超过额定压力或额定工作温度范围会导致球阀的泄漏和损坏。

维修前注意事项:

1. 执行器的电源必须切断。
2. 不能由无关人员开启设备。
3. 排净管道系统内的液体并释放压力。
4. 必须警惕残余液体的危险性。
5. 穿戴必要的防护服及用品(衣服、帽子、眼镜等)
6. 球阀需冷却后再安装。
7. 不要超过规定极限范围内的压力、温度和介质。

KHB系列球阀

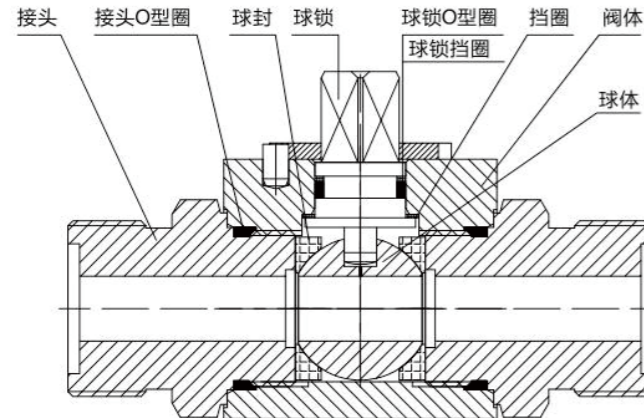

KHB系列二通球阀总装示意图

概述：

符合 DIN ISO 1219, 宁波怡盛液压高压球阀用于截断工作介质的正反向流动。

功能原理：

旋转球锁使球体从开启位置切换到关闭位置, 系统压力将球体推向球封的无压侧并无泄漏的切断液流。

应用：

宁波怡盛液压高压球阀用于截断液路中的液流, 应用场合有机床、工程机械、农业机械、系统流程等。

注释：

球阀不是设计为流量控制阀, 所以要么全开要么全关, 以免损坏密封。为确保正确运转, 必须注意压力和温度说明, 等同于管螺纹连接的允许工作压力。

KHB-L KHB-S

管端24°锥/管端24°锥

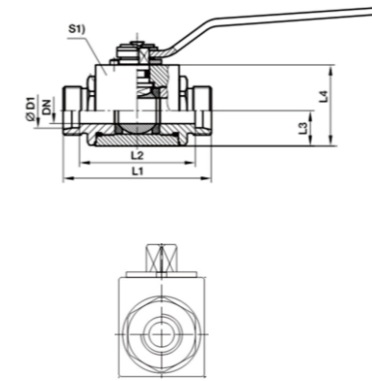

系列	产品代号 PARTNO.	螺纹 THREAD	管子外径 TUBE O.D	尺寸 DIMENSIONS						工作压力 (bar)	
		T	D1	DN	L1	L2	L3	L4	S1	碳钢 (CF)	
L	KHB-06L	M12X1.5	6	4	67	40	13	32	26	500	
	KHB-08L	M14X1.5	8	6	67	40	13	32	26	500	
	KHB-10L	M16X1.5	10	8	74	42	17	40	34	500	
	KHB-12L	M18X1.5	12	10	74	42	17	40	34	500	
	KHB-15L	M22X1.5	15	12	82	48	17	40	34	500	
	KHB-18L	M26X1.5	18	12	82	48	17	40	34	500	
	KHB-18LB	M26X1.5	18	16	82	48	19	46	38	400	
	KHB-22L	M30X2.0	22	20	101	60	24	56	48	315	
	KHB-28L	M36X2.0	28	25	108	64	29	63	58	315	
S	KHB-35L	M45X2.0	35	32	141	72	34	75	68	315	
	KHB-42L	M52X2.0	42	40	162	80	40	86	80	315	
	KHB-06S	M14X1.5	6	4	73	40	13	32	26	500	
	KHB-08S	M16X1.5	8	6	73	40	13	32	26	500	
	KHB-10S	M18X1.5	10	8	76	42	17	40	34	500	
	KHB-12S	M20X1.5	12	10	80	42	17	40	34	500	
	KHB-14S	M22X1.5	14	12	86	48	17	40	34	500	
	KHB-16S	M24X1.5	16	12	90	48	17	40	34	500	
	KHB-20S	M30X2.0	20	16	90	48	19	46	38	400	
	KHB-25S	M36X2.0	25	20	109	60	24	56	48	315	
KHB-30S	M42X2.0	30	25	120	64	29	63	58	315		
KHB-38S	M52X2.0	38	32	153	72	34	75	68	315		

KHB3K系列球阀

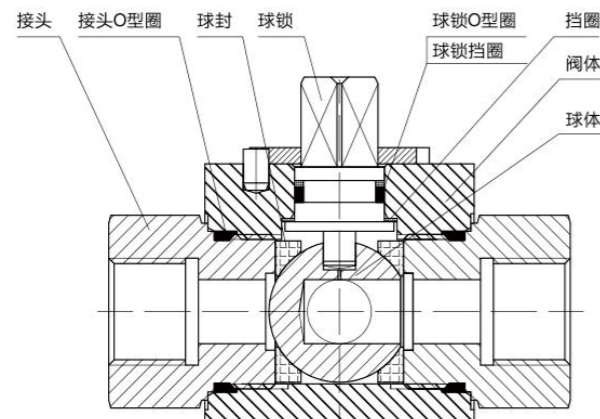

概述：

符合 DIN 2429, 宁波怡盛液压2位3通高压球阀用于截断工作介质的正反向流动。

功能原理：

旋转球锁使液体按球口形状换向, 同时无泄漏地截断对立的一侧, 系统压力把球体推向密封的无压侧, 球体无泄漏地截断从进口到出口口的液流。

应用：

宁波怡盛液压2位3通高压球阀用于使液路回路中的液流换向, 应用场合有机床、工程机械、农业机械、系统流程等。

注释：

球阀不是设计为流量控制阀, 所以要么全开要么全关, 以免损坏密封。为确保正确运转, 必须注意压力和温度说明, 等同于管螺纹连接的允许工作压力。

KHB3K-L KHB3K-S

三通球阀
管端24°锥/
管端24°锥/
管端24°锥

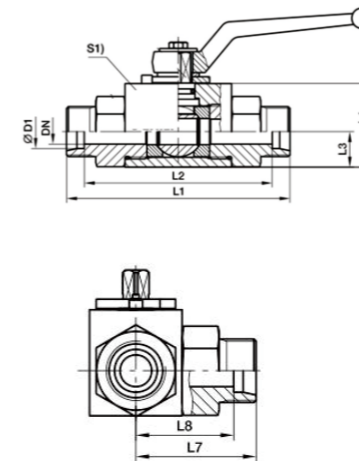

系列	产品代号 PART NO.	螺纹 THREAD	管子外径 TUBE O.D	尺寸 DIMENSIONS								工作压力 (bar)	
		T	D1	DN	L1	L2	L3	L4	L7	L8	S1	碳钢 (CF)	
L	KHB3K-06L	M12X1.5	6	4	67	53	13	32	35.0	28.0	28	500	
	KHB3K-08L	M14X1.5	8	6	67	53	13	32	35.0	28.0	28	500	
	KHB3K-10L	M16X1.5	10	8	74	60	17	40	35.5	28.5	35	500	
	KHB3K-12L	M18X1.5	12	10	74	60	17	40	35.5	28.5	35	500	
	KHB3K-15L	M22X1.5	15	12	82	68	17	40	40.0	33.0	35	500	
	KHB3K-18L	M26X1.5	18	12	82	67	17	40	42.0	34.5	35	500	
	KHB3K-18LB	M26X1.5	18	16	82	67	19	46	42.0	34.5	38	400	
	KHB3K-22L	M30X2.0	22	20	101	86	24	56	52.0	44.5	48	315	
	KHB3K-28L	M36X2.0	28	25	108	93	29	63	53.5	46.0	58	315	
S	KHB3K-35L	M45X2.0	35	32	112	91	34	75	56.0	45.5	68	315	
	KHB3K-08S	M16X1.5	6	4	73	59	13	32	37.0	30.0	28	500	
	KHB3K-10S	M18X1.5	8	6	73	59	13	32	37.0	30.0	28	500	
	KHB3K-12S	M20X1.5	10	8	76	61	17	40	37.5	30.0	35	500	
	KHB3K-14S	M22X1.5	12	10	80	64	17	40	38.5	30.5	35	500	
	KHB3K-16S	M24X1.5	14	12	86	69	17	40	43.5	35.0	35	500	
	KHB3K-20S	M30X2.0	16	12	90	69	17	40	45.5	35.0	35	500	
	KHB3K-20S	M30X2.0	20	16	90	69	19	46	45.5	35.0	38	400	
	KHB3K-25S	M36X2.0	25	20	109	85	24	56	56.0	44.0	48	315	
	KHB3K-30S	M42X2.0	30	25	120	93	29	63	59.5	46.0	58	315	
KHB3K-38S	M52X2.0	38	32	153	121	34	75	62.0	46.0	68	315		

KHB-G

英制BSPP内螺纹/
英制BSPP内螺纹

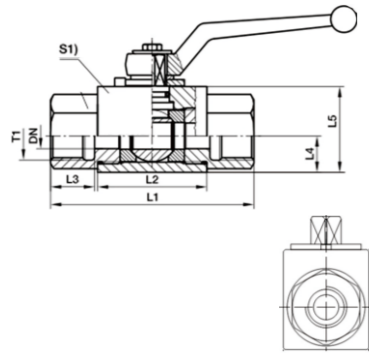

产品代号 PART NO.	螺纹THREAD	尺寸 DIMENSIONS							工作压力 (bar)	
	T1	DN	L1	L2	L3	L4	L5	S1	碳钢(CF)	
KHB-G02	G1/8"	4	69	40	10	13	32	26	500	
KHB-G04	G1/4"	6	69	40	14	13	32	26	500	
KHB-G06	G3/8"	10	72	42	14	17	40	34	500	
KHB-G08	G1/2"	12	83	48	16	17	40	34	500	
KHB-G08B	G1/2"	16	83	48	16	19	46	38	400	
KHB-G12	G3/4"	20	95	60	18	24	56	48	315	
KHB-G16	G1"	25	113	64	20	29	63	58	315	
KHB-G20	G1.1/4"	32	110	72	22	34	75	68	315	
KHB-G24	G1.1/2"	40	130	80	24	40	86	80	315	
KHB-G32	G2"	50	140	96	26	48	102	96	315	

KHB-NPT

美制NPT内螺纹/
美制NPT内螺纹

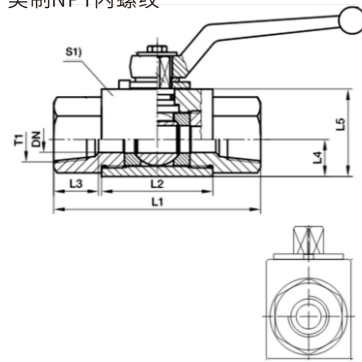

产品代号 PART NO.	螺纹THREAD	尺寸 DIMENSIONS							工作压力 (bar)	
	T1	DN	L1	L2	L3	L4	L5	S1	碳钢(CF)	
KHB-02NPT	Z1/8" NPT	4	69	40	10	13	32	26	500	
KHB-04NPT	ZG1/4" NPT	6	69	40	14	13	32	26	500	
KHB-06NPT	ZG3/8" NPT	10	72	42	14	17	40	34	500	
KHB-08NPT	ZG1/2" NPT	12	83	48	16	17	40	34	500	
KHB-08NPTB	ZG1/2" NPT	16	83	48	16	19	46	38	400	
KHB-12NPT	ZG3/4" NPT	20	95	60	18	24	56	48	315	
KHB-16NPT	ZG1" NPT	25	113	64	20	29	63	58	315	
KHB-20NPT	ZG1.1/4" NPT	32	110	72	22	34	75	68	315	
KHB-24NPT	ZG1.1/2" NPT	40	130	80	24	40	86	80	315	
KHB-32NPT	ZG2" NPT	50	140	96	26	48	102	96	315	

KHB3K-G

三通球阀
英制BSPP内螺纹/
英制BSPP内螺纹/英
制BSPP内螺纹

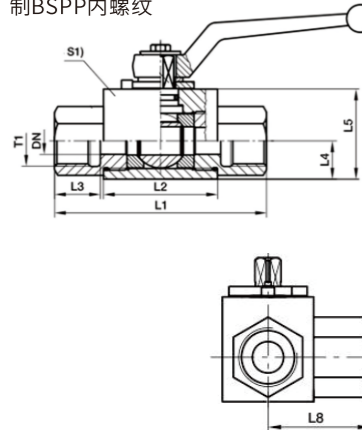

产品代号 PART NO.	螺纹THREAD	尺寸 DIMENSIONS								工作压力 (bar)	
	T1	DN	L1	L2	L3	L4	L5	L8	S1	碳钢(CF)	
KHB3K-G02	G1/8"	4	69	40	10	13	32	35.0	28	500	
KHB3K-G04	G1/4"	6	69	40	14	13	32	35.0	28	500	
KHB3K-G06	G3/8"	10	72	42	14	17	40	34.5	35	500	
KHB3K-G08	G1/2"	12	83	48	16	17	40	40.0	35	500	
KHB3K-G08B	G1/2"	16	83	48	16	19	46	42.0	38	400	
KHB3K-G12	G3/4"	20	95	60	18	24	56	49.0	48	315	
KHB3K-G16	G1"	25	113	64	20	29	63	56.0	58	315	
KHB3K-G20	G1.1/4"	25	120	64	22	29	63	58.5	58	315	
KHB3K-G20B	G1.1/4"	32	110	72	22	34	75	58.5	68	315	
KHB3K-G24	G1.1/2"	40	130	80	24	40	86	67.5	80	315	
KHB3K-G32	G2"	50	140	96	26	48	102	70.0	96	315	

SF-AC

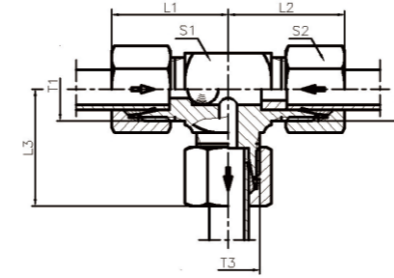

使用止阀时,当介质从进口T1进入时,浮动铜球在介质动力作用下,自动将进口T2关闭。反之亦然。

These valves permit the passage of flow from either inlet T1 or T2 to the outlet port whilst shutting of the inlet port not in use. The shutting off, of an inlet is achieved by a floating ball bearing which moves by the pressure of the flow.

通流方向: D1 D3时D2关闭
D2 D3时D1关闭

材 料: 碳钢, 三价铬
温 度: -40°C~+120 °C
泄 漏: 最高压力Pmax下每分钟20滴泄漏量

代号 PART NO.	螺纹 THREAD			管子外径 φ O.D. D1-3	尺寸 DIMENSIONS					重量 克/件	最大工作压力 (bar)
	T1	T2	T3		L1	L2	L3	S1	S2		
SF-AC-14	M14x1.5	M14x1.5	M14x1.5	08	29	29	29	17	17	107	250
SF-AC-16	M16x1.5	M16x1.5	M16x1.5	10	30	30	30	17	19	131	250
SF-AC-18	M18x1.5	M18x1.5	M18x1.5	12	32	32	32	19	22	175	250
SF-AC-22	M22x1.5	M22x1.5	M22x1.5	15	36	36	36	19	27	253	250

SF-AF

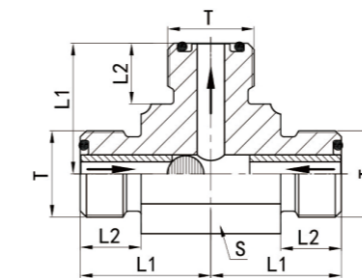

使用止阀时,当介质从进口T1进入时,浮动铜球在介质动力作用下,自动将进口T2关闭。反之亦然。

These valves permit the passage of flow from either inlet T1 or T2 to the outlet port whilst shutting of the inlet port not in use. The shutting off, of an inlet is achieved by a floating ball bearing which moves by the pressure of the flow.

通流方向: D1 D3时D2关闭
D2 D3时D1关闭

材 料: 碳钢, 三价铬
温 度: -40°C~+120 °C
泄 漏: 最高压力Pmax下每分钟20滴泄漏量

代 号 PART NO.	螺纹 THREAD	管子外径 φ O.D. D1-3	尺寸 DIMENSIONS			重量 克/件	最大工作压力 (bar)
	T		L1	L2	S1		
SF-AF-04	9/16" -18UNF	6	21.5	10	17	135	250
SF-AF-06	11/16" -16UN	10	25.0	11	19	191	250
SF-AF-08	13/16" -16UN	12	28.0	13	22	278	250

附加资料

ADDITIONAL INFORMATION

O形圈 O-Ring

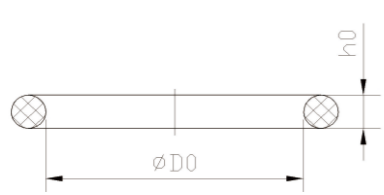

DIN24°锥轻系列O形圈密封用O形圈 ForDIN 24°cone O-Ring L.T.				
O形圈代号	螺纹	尺寸DIMENSIONS		管子外径
PART NO.	THREAD	D0	h0	TUBE O.D.
O04.5X1.5	M12X1.5	4.5	1.5	06
O06.5X1.5	M14X1.5	6.5	1.5	08
O08.0X1.5	M16X1.5	8.0	1.5	10
O10.0X1.5	M18X1.5	10.0	1.5	12
O12.0X2.0	M22X1.5	12.0	2.0	15
O15.0X2.0	M26X1.5	15.0	2.0	18
O20.0X2.0	M30X2.0	20.0	2.0	22
O26.0X2.0	M36X2.0	26.0	2.0	28
O32.0X2.5	M45X2.0	32.0	2.5	35
O38.0X2.5	M52X2.0	38.0	2.5	42

DIN24°锥重系列O形圈密封用O形圈 ForDIN 24° cone O-Ring H.T.				
O形圈代号	螺纹	尺寸DIMENSIONS		管子外径
PART NO.	THREAD	D0	h0	TUBE O.D.
O04.5X1.5	M14X1.5	4.5	1.5	06
O06.5X1.5	M16X1.5	6.5	1.5	08
O08.0X1.5	M18X1.5	8.0	1.5	10
O10.0X1.5	M20X1.5	10.0	1.5	12
O12.0X2.0	M24X1.5	12.0	2.0	16
O16.3X2.4	M30X2.0	20.0	2.0	20
O20.3X2.4	M36X2.0	26.0	2.0	25
O25.3X2.4	M42X2.0	32.0	2.5	30
O35.3X2.4	M52X2.0	38.0	2.5	38

ISO 6162法兰用O形圈 ForISO6162 flange O-Ring			
O形圈代号	法兰尺寸	尺寸DIMENSIONS	
PART NO.	FLANGE SIZE	D0	h0
O19.0X3.55	1/2"	19	3.55
O25.0X3.55	3/4"	25	3.55
O32.5X3.55	1"	32.5	3.55
O37.5X3.55	1.1/4"	37.5	3.55
O47.5X3.55	1.1/2"	47.5	3.55
O56.0X3.55	2"	56	3.55

美制SAE外螺纹柱端O形圈密封用O形圈 ForSAE male O-Ring			
O形圈代号	螺纹	尺寸DIMENSIONS	
PART NO.	THREAD	D0	h0
O08.92X1.83	7/16"X20UNF	8.92	1.83
O10.52X1.83	1/2"X20UNF	10.52	1.83
O11.89X1.98	9/16"X18UNF	11.89	1.98
O16.36X2.21	3/4"X16UNF	16.36	2.21
O19.18X2.46	7/8"X14UNF	19.18	2.46
O23.47X2.95	1.1/16"X12UN	23.47	2.95
O26.62X2.95	1.3/16"X12UN	26.62	2.95
O29.74X2.95	1.5/16"X12UN	29.74	2.95
O37.46X3.00	1.5/8"X12UN	37.46	3.0
O43.69X3.00	1.7/8"X12UN	43.69	3.0
O59.36X3.00	2.1/2"X12UN	59.36	3.0

英管内螺纹60°外锥面带O形圈密封用O形圈 ForBSP 60° CONE O-RING			
O形圈代号	螺纹	尺寸DIMENSIONS	
PART NO.	THREAD	D0	h0
O06.11X1.0	G1/4"X19	6.1	1
O08.1X1.6	G3/8"X19	8.1	1.6
O12.1X1.6	G1/2"X14	12.1	1.6
O13.1X1.6	G5/8"X14	13.1	1.6
O17.1X1.6	G3/4"X14	17.1	1.6
O22.1X1.6	G1"X11	22.1	1.6
O29.1X1.6	G1.1/4"X11	29.1	1.6
O35.1X1.6	G1.1/2"X11	35.1	1.6
O47.37X1.78	G2"X11	47.37	1.78

ISO 6149公制外螺纹柱端O形圈密封用O形圈 Formetric male stud end O-Ring			
O形圈代号	螺纹	尺寸DIMENSIONS	
PART NO.	THREAD	D0	h0
O06.1X1.6	M8X1.0	6.1	1.6
O08.1X1.6	M10X1.0	8.1	1.6
O09.3X2.2	M12X1.5	9.3	2.2
O11.3X2.2	M14X1.5	11.3	2.2
O13.3X2.2	M16X1.5	13.3	2.2
O15.3X2.2	M18X1.5	15.3	2.2
O19.3X2.2	M22X1.5	19.3	2.2
O23.6X2.9	M27X2.0	23.6	2.9
O26.6X2.9	M30X2.0	26.6	2.9
O29.6X2.9	M33X2.0	29.6	2.9
O38.6X2.9	M42X2.0	38.6	2.9
O44.6X2.9	M48X2.0	44.6	2.9
O56.6X2.9	M60X2.0	56.6	2.9

公制外螺纹柱端O形圈密封用O形圈 Formetric male stud end O-Ring			
O形圈代号	螺纹	尺寸DIMENSIONS	
PART NO.	THREAD	D0	h0
O06.1X1.6	M8X1.0	6.1	1.6
O08.1X1.6	M10X1.0	8.1	1.6
O09.3X2.4	M12X1.5	9.3	2.4
O11.3X2.4	M14X1.5	11.3	2.4
O13.3X2.4	M16X1.5	13.3	2.4
O15.3X2.4	M18X1.5	15.3	2.4
O17.3X2.4	M20X1.5	17.3	2.4
O19.3X2.4	M22X1.5	19.3	2.4
O21.3X2.4	M24X1.5	21.3	2.4
O23.5X3.0	M26X1.5	23.5	3.0
O23.5X3.0	M27X2.0	23.5	3.0
O26.5X3.0	M30X2.0	26.5	3.0
O29.5X3.0	M33X2.0	29.5	3.0
O38.5X3.0	M42X2.0	38.5	3.0
O44.5X3.0	M48X2.0	44.5	3.0
O56.6X3.0	M60X2.0	56.6	3.0



O形圈 O-Ring

JIS B8363英制外螺纹柱端O形圈密封用O形圈 For BSPPmale stud end O-Ring JIS B8363				
O形圈代号	螺纹	尺寸DIMENSIONS		O形圈代码
PART NO.	THREAD	D0	h0	
O10.8X2.4	G1/4	10.8	2.4	P11
O13.8X2.4	G3/8	13.8	2.4	P14
O17.8X2.4	G1/2	17.8	2.4	P18
O23.7X3.5	G3/4	23.7	3.5	P24
O28.7X3.5	G1	28.7	3.5	P29
O37.7X3.5	G1.1/4	37.7	3.5	P38
O43.7X3.5	G1.1/2	43.7	3.5	P44

JIS B2351英制外螺纹柱端O形圈密封用O形圈 For BSPPmale stud end O-Ring JIS B2351				
O形圈代号	螺纹	尺寸DIMENSIONS		O形圈代码
PART NO.	THREAD	D0	h0	
O07.8X1.9	G1/8	7.8	1.9	P8
O10.8X2.4	G1/4	10.8	2.4	P11
O13.8X2.4	G3/8	13.8	2.4	P14
O17.8X2.4	G1/2	17.8	2.4	P18
O23.7X3.5	G3/4	23	3.5	P22.4
O28.7X3.5	G1	28.7	3.5	P29
O37.7X3.5	G1.1/4	37.7	3.5	P38
O43.7X3.5	G1.1/2	43.7	3.5	P44

美制ORFS外螺纹O形圈密封用O形圈 For ORFS male O-Ring			
O形圈代号	螺纹	尺寸DIMENSIONS	
PART NO.	THREAD	D0	h0
O07.65X1.78	9/16"X18UNF	7.65	1.78
O09.25X1.78	11/16"X16UN	9.25	1.78
O12.42X1.78	13/16"X16UN	12.42	1.78
O15.60X1.78	1"X14UNF	15.6	1.78
O18.77X1.78	1.3/16"X12UN	18.77	1.78
O23.52X1.78	1.7/16"X12UN	23.52	1.78
O29.87X1.78	1.11/16"X12UN	29.87	1.78
O37.82X1.78	2"X12UN	37.82	1.78

英管外螺纹柱端O形圈密封用O形圈 For BSP male stud end O-Ring			
O形圈代号	螺纹	尺寸DIMENSIONS	
PART NO.	THREAD	D0	h0
O10.77X2.62	G1/4"X19	10.77	2.62
O13.94X2.62	G3/8"X19	13.94	2.62
O17.12X2.62	G1/2"X14	17.12	2.62
O19.18X2.46	G5/8"X14	19.18	2.46
O23.47X2.62	G3/4"X14	23.47	2.62
O29.74X3.53	G1"X11	29.74	3.53
O37.69X3.53	G1.1/4"X11	37.69	3.53
O44.04X3.53	G1.1/2"X11	44.04	3.53
O54.0X3.0	G2"X11	54	3

**胶 垫
CAPTIVE SEAL**

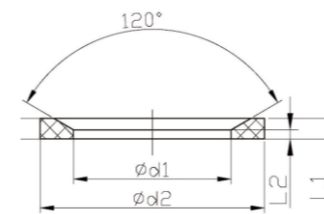

胶垫代号	适用螺纹	尺寸 DIMENSIONS				
PART NO.	THREAD	d1	d2	L1±0.1	L2±0.2	
WD-B02	G1/8"X28	8.4	±0.2	11.9	1	0.5
WD-B04	G1/4"X19	11.6		16.5	1.5	0.8
WD-B06	G3/8"X19	14.7		18.9	1.5	0.8
WD-B08	G1/2"X14	18.5		23.9	1.5	0.8
WD-B12	G3/4"X14	23.9	±0.3	29.2	1.5	0.8
WD-B16	G1"X11	29.7		35.7	2	1
WD-B20	G1.1/4"X11	38.8		45.8	2	1
WD-B24	G1.1/2"X11	44.7		50.7	2	1
WD-B02	M10X1	8.4	±0.2	11.9	1	0.5
WD-M12	M12X1.5	9.8		14.4	1	0.5
WD-B04	M14X1.5	11.6		16.5	1.5	0.8
WD-M16	M16X1.5	13.8		18.9	1.5	0.8
WD-M18	M18X1.5	15.7	±0.2	20.9	1.5	0.8
WD-M20	M20X1.5	17.8		22.9	1.5	0.8
WD-M22	M22X1.5	19.6		24.3	1.5	0.8
WD-B12	M26X1.5	23.9		29.2	1.5	0.8
WD-B12	M27XX2.0	23.9	±0.2	29.2	1.5	0.8
WD-B16	M33X2.0	29.7		35.7	2	1
WD-B20	M42X2.0	38.8		45.8	2	1
WD-B24	M48X2.0	44.7		50.7	2	1
WD-B32	G2"X11	56.5	±0.3	66.5	4	2

1、ISO 9974-1 公制螺纹油口及相配柱端
ISO 9974-1 metric thread port and mating stud end

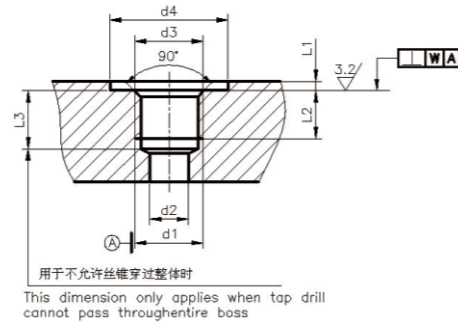
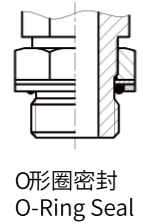
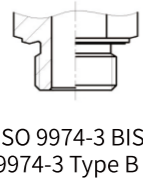

ISO 9974-1油口 Port

螺纹 Thread d1	d2 参考ref.	d3		d4 min.	L1 max.	L2 min.	L3 min.	w
		尺寸nom.	公差tol.					
M8X1.0	3	8	0,+0.2	13	1	8	10	0.1
M10X1.0	4.5	10	0,+0.2	15	1	8	10	0.1
M12X1.5	6	12	0,+0.2	18	1.5	12	15	0.1
M14X1.5	7	14	0,+0.2	20	1.5	12	15	0.1
M16X1.5	9	16	0,+0.2	23	1.5	12	15	0.1
M18X1.5	11	18	0,+0.2	25	2	12	15	0.1
M20X1.5	10	20	0,+0.2	27	2	14	17	0.1
M22X1.5	14	22	0,+0.2	28	2.5	14	17	0.1
M26X1.5	18	26	0,+0.2	33	2.5	16	19	0.2
M27X2.0	16	27	0,+0.2	33	2.5	16	20	0.2
M33X2.0	23	33	0,+0.3	41	2.5	18	22	0.2
M42X2.0	30	42	0,+0.3	51	2.5	20	24	0.2
M48X2.0	36	48	0,+0.3	56	2.5	22	36	0.2

适用于ISO 9974-1 油口柱端螺纹拧紧力矩(N.m)							
产品系列	螺纹规格	WD垫圈密封 拧紧力矩	O形圈加 挡圈密封	尖角硬密封	铰接式 KDS密封	可调向接头O形 圈加挡圈密封	内六角堵头 WD垫圈密封
轻系列 L	M10X1.0	18	18	20	18	18	12
	M12X1.5	25	35	30	45	35	25
	M14X1.5	45	45	50	55	45	35
	M16X1.5	55	55	70	80	55	50
	M18X1.5	70	70	90	100	70	65
	M22X1.5	125	160	150	140	180	90
	M26X1.5	180	250	210	320	180	135
	M33X2.0	310	310	380	360	310	225
	M42X2.0	450	450	550	540	450	360
	M48X2.0	540	540	700	700	600	360
重系列 S	M12X1.5	40		45	45	35	
	M14X1.5	40		60	55	60	
	M16X1.5	70		90	80	95	
	M18X1.5	90		120	100	120	
	M22X1.5	135		190	135	190	
	M27X2.0	180		320	320	190	
	M33X2.0	310		450	360	500	
	M42X2.0	450		600	540	600	
M48X2.0	540		800	700	600		

2、ISO6149-1 公制螺纹油口及相配柱端
ISO6149-1 metric thread port and mating stud end

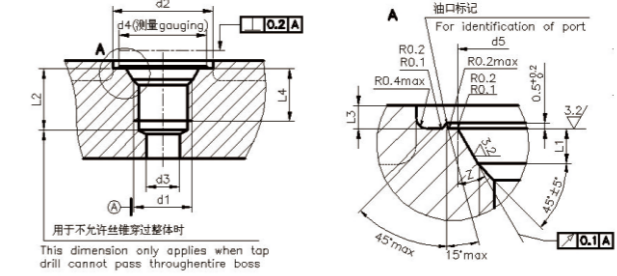
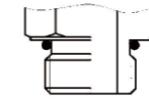

ISO6149-1油口 Port

螺纹 Thread di	d2		d3 参考 ref.	d4	d5 +0.1 0	d6 +0.5 0	L1 +0.4 0	L2 min.	L3 max.	L4 min.	Z°±1°	O形圈 O-RING
	min ¹⁾	min ²⁾										
M8X1.0	17	14	3	12.5	9.1	14	1.6	11.5	1	10	12	6.1X1.6
M10X1.0	20	16	4.5	14.5	11.1	16	1.6	11.5	1	10	12	8.1X1.6
M12X1.5	23	19	6	17.5	13.8	19	2.4	14	1.5	11.5	15	9.3X2.2
M14X1.5	25	21	7.5	19.5	15.8	21	2.4	14	1.5	11.5	15	11.3X2.2
M16X1.5	28	24	9	22.5	17.8	24	2.4	15.5	1.5	13	15	13.3X2.2
M18X1.5	30	26	11	24.5	19.8	26	2.4	17	2	14.5	15	15.3X2.2
M20X1.5	32	27	--	25.5	21.8	27	2.4	--	2	14.5	15	17.3X2.2
M22X1.5	34	29	14	27.5	23.8	29	2.4	18	2	15.5	15	19.3X2.2
M27X2.0	40	34	18	32.5	29.4	34	3.1	22	2	19	15	23.6X2.9
M33X2.0	49	43	23	41.5	35.4	43	3.1	22	2.5	19	15	29.6X2.9
M42X2.0	60	52	30	50.5	44.4	52	3.1	22.5	2.5	19.5	15	38.6X2.9
M48X2.0	66	57	36	55.5	50.4	57	3.1	25	2.5	22	15	44.6X2.9
M60X2.0	76	67	44	65.5	62.4	67	3.1	27.5	2.5	24.5	15	56.6X2.9

适用于ISO 6149-1 油口柱端螺纹拧紧力矩(N.m)				
产品系列	螺纹规格	O形圈密封	可调向接头O形圈密封	内六角堵头O形圈密封
轻系列 L	M10X1.0	15	15	20
	M12X1.5	25	25	35
	M14X1.5	35	35	45
	M16X1.5	40	40	55
	M18X1.5	45	45	70
	M22X1.5	60	60	100
	M26X1.5	100	100	135
	M33X2.0	160	160	310
	M42X2.0	210	210	330
	M48X2.0	260	260	420
重系列 S	M12X1.5	35	35	35
	M14X1.5	45	45	45
	M16X1.5	55	55	55
	M18X1.5	70	90	70
	M22X1.5	100	100	100
	M27X2.0	170	170	170
	M33X2.0	310	310	310
	M42X2.0	330	330	330
M48X2.0	420	420	420	

3、DIN3582、ISO 1179 英管螺纹油口及相配柱端 DIN3582 BSP thread port and mating stud end

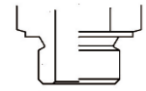

DIN 3852 A型柱端
DIN 3852 Type A

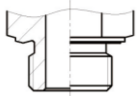

DIN 3852 B型柱端
DIN 3852 Type B

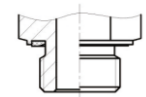

DIN 3852 E型柱端
DIN 3852 Type E
ISO1179WD垫圈

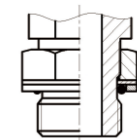

O形圈密封
O-Ring Seal

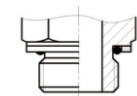

O形圈密封
O-Ring Seal

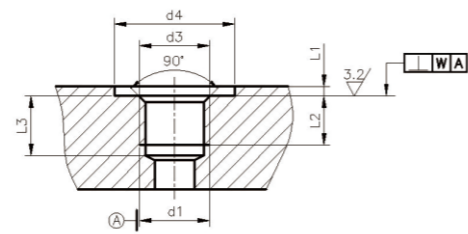

DIN 3852油口 Port

螺纹 Thread d1	d3		d4+0.4 0		L1 max.	L2 min.	L3 min.	w
			B、E型柱端 Type B、E	其它 Others				
G1/8X28	9.8	0,+0.2	15	19	1	8	10	0.1
G1/4X19	13.2	0,+0.2	20	25	1.5	12	15	0.1
G3/8X19	16.7	0,+0.2	23	28	2	12	15	0.1
G1/2X14	21	0,+0.2	28	34	2.5	14	18	0.1
G3/4X14	26.5	0,+0.2	33	42	2.5	16	20	0.2
G1X11	33.3	0,+0.3	41	47	2.5	18	23	0.2
G1.1/4X11	42	0,+0.3	51	58	2.5	20	25	0.2
G1.1/2X11	47.9	0,+0.3	56	65	2.5	22	27	0.2
G2"X11	59.7	0,+0.3	69	76	3	24	29	0.2

适用于ISO 1179-1、DIN3852油口柱端螺纹拧紧力矩(N.m)							
产品系列	螺纹规格	WD垫圈密封拧紧力矩	O形圈加挡圈密封	尖角硬密封	铰接式KDS密封	可调向接头O形圈加挡圈密封	内六角堵头WD垫圈密封
轻系列 L	G1/8A	18	18	20	18	18	130
	G1/4A	35	35	40	45	35	30
	G3/8A	70	70	80	70	70	60
	G1/2A	90	105	150	120	110	80
	G3/4A	180	180	200	230	180	140
	G1A	310	310	380	320	310	200
	G1.1/4A	450	450	600	540	450	400
G1.1/2A	540	540	700	700	540	450	
重系列 S	G1/8A					25	13
	G1/4A	40		60	45	55	30
	G3/8A	80		100	70	90	60
	G1/2A	115		170	120	110	80
	G3/4A	180		320	230	200	140
	G1A	310		380	320	420	200
	G1.1/4A	450		600	540	550	400
G1.1/2A	540		800	700	600	450	

4、BS5380英管螺纹油口及相配柱端 BS5380 BSP thread port and mating stud end

BS 5380油口 Port

螺纹 Thread di	d2 min.	d3 max.	d5 +0.12 0	L1 +0.4 0	L3 max.	L4 min.	O形圈 O-RING
G1/8X28	15	14	11.24	1.3	0.6	10.5	8.1X1.6
G1/4X19	19	18	14.16	1.2	0.6	11.0	10.1X1.6
G3/8X19	23	22	18.86	1.9	0.6	12.5	13.6X2.4
G1/2X14	27	26	22.40	1.9	0.8	15.0	17.6X2.4
G5/8X14	31	30	26.00	2.4	0.8	16.3	19.5X3.0
G3/4X14	33	32	28.92	2.4	1.1	16.3	22.5X3.0
G1X11	40	39	35.50	2.4	1.1	19.1	29.5X3.0
G1.1/4X11	50	49	43.56	2.4	1.1	21.4	36.5X3.0
G1.1/2X11	56	55	49.42	2.4	1.1	22.5	42.5X3.0
G2X11	69	68	61.42	2.4	1.1	25.7	54.5X3.0

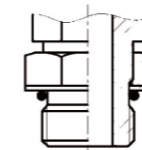

BS 5380柱端

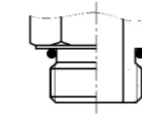

BS 5380 stud end

5、JIS B 2351 英管螺纹油口及相配柱端 JIS B 2351 BSP thread port and mating stud end

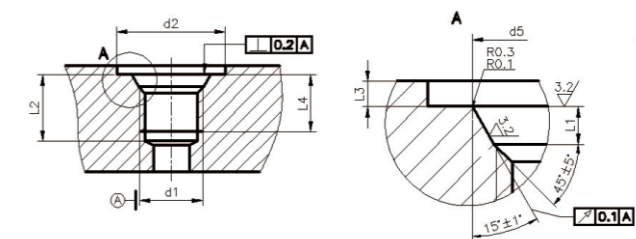

JIS B 2351油口 Port

螺纹 Thread di	d2 ±0.3	d5 +0.1 0	L1 +0.4 0	L2 min.	L3 max.	L4 min.	O形圈 O-RING
G1/8X28	18	11.6	2.0	15	1.0	10	7.8X1.9
G1/4X19	24	15.6	2.5	18	1.5	12	10.8X2.4
G3/8X19	28	18.6	2.5	18	2.0	12	13.8X2.4
G1/2X14	34	22.6	2.5	24	2.5	16	17.8X2.4
G3/4X14	45	29.8	3.5	25	2.5	17	23.0X3.5
G1X11	51	35.8	3.5	30	2.5	21	28.7X3.5
G1.1/4X11	62	44.8	3.5	30	2.5	21.4	37.7X3.5
G1.1/2X11	68	50.8	3.5	30	2.5	21.4	43.7X3.5



JIS B 2351柱端

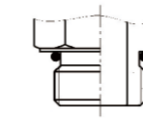

JIS B 2351 stud end

6、ISO11926-1美制螺纹油口及相配柱端 ISO11926-1 SAE thread port and mating stud end

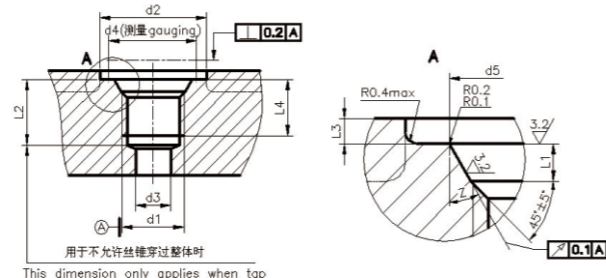
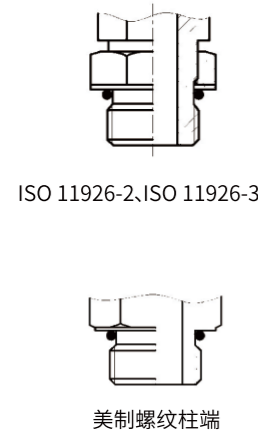

ISO 11926-1美制螺纹油口 ISO 11926-1 SAE thread port

螺纹 Thread	d2 min.	d3 参考 ref.	d4 min.	d5 ±0.05	L1 +0.4 0	L2 min.	L3 max.	L4 min.	Z ±1°	O形圈 O-RING
5/16"X24UNF	17	2.5	11	9.15	1.9	12	1.6	10	12	6.07X1.63
3/8"X24UNF	19	3.5	13	10.75	2.4	12	1.6	10	12	7.65X1.63
7/16"X20UNF	21	4.5	15	12.45	2.4	14	1.6	11.5	12	8.92X1.83
1/2"X20UNF	23	6	16	14.05	2.5	14	1.6	11.5	12	10.52X1.83
9/16"X18UNF	25	7.5	18	15.70	2.5	15.5	1.6	12.7	12	11.89X1.98
3/4"X16UNF	30	10	22	20.65	2.5	17.5	2.4	14.3	15	16.36X2.21
7/8"X14UNF	34	12.5	26	24	2.5	20	2.4	16.7	15	19.18X2.46
1.1/16"X12UN	41	16	32	29.2	3.3	23	2.4	19	15	23.47X2.95
1.3/16"X12UN	45	18	35	32.4	3.3	23	2.4	19	15	26.62X2.95
1.5/16"X12UN	49	21	38	35.55	3.3	23	3.2	19	15	29.74X2.95
1.5/8"X12UN	58	27	48	43.55	3.3	23	3.2	19	15	37.46X3.00
1.7/8"X12UN	65	33	54	49.9	3.3	23	3.2	19	15	43.69X3.00
2.1/2"X12UN	88	45	70	65.75	3.3	23	3.2	19	15	59.36X3.00

适用于ISO 11926-1 油口柱端螺纹拧紧力矩(N.m)				
产品系列	螺纹规格	O形圈密封	可调向接头O形圈密封	内六角堵头O形圈密封
轻系列 L	7/16-20UNF-2A	23	18	18
	1/2-20UNF-2A	28	28	28
	9/16-18UNF-2A	34	34	34
	3/4-16UNF-2A	60	55	55
	7/8-14UNF-2A	115	80	80
	1.1/16-12UN-2A	140	100	95
	1.5/16-12UN-2A	210	150	150
	1.5/8-12UN-2A	290	290	290
重系列 S	1.7/8-12UN-2A	325	325	320
	7/16-20UNF-2A	20	20	
	1/2-20UNF-2A	40	40	
	9/16-18UNF-2A	46	46	
	3/4-16UNF-2A	80	80	
	7/8-14UNF-2A	135	135	
	1.1/16-12UN-2A	185	185	
	1.5/16-12UN-2A	270	270	
1.5/8-12UN-2A	340	340		
1.7/8-12UN-2A	415	415		

7、锥管螺纹油口 Taper Thread Port

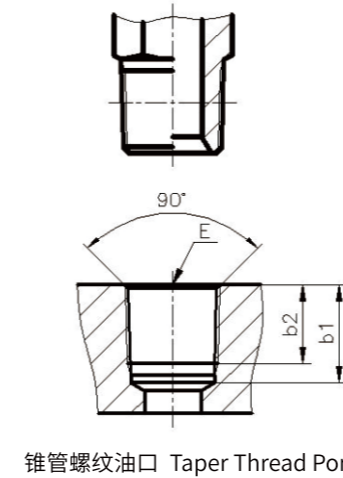

螺纹 Thread E	b1 min.	b2 min.
Rc1/8x28	9.5	7.5
Rc1/4x19	13.5	11
Rc3/8x19	14	11.5
Rc1/2x14	17.5	15
Rc3/4x14	19	16.5
Rc1x11	22.5	19.5
Rc1.1/4x11	24.8	21.5
Rc1.1/2x11	24.8	21.5
Rc2x11	29.5	26
Z1/8x27	10	7.8
Z1/4x18	14	11.8
Z3/8x18	14	11.8
Z1/2x14	18	15.5
Z3/4x14	18.5	16
Z1x11.5	22.5	19.5
Z1.1/4x11.5	24	20.5
Z1.1/2x11.5	24	20.5
Z2x11.5	25	21.5

8、ISO6162 法兰油口 ISO6162 Flange Port

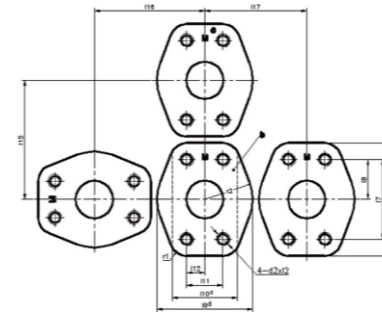

3000PSI系列 (Code61) 法兰推荐力矩						6000PSI系列 (Code62) 法兰推荐力矩					
标号	尺寸	美制螺纹 J518	力矩 (N.m)	公制螺纹 ISO6162	力矩 (N.m)	标号	尺寸	美制螺纹 J518	力矩 (N.m)	公制螺纹 ISO6162	力矩 (N.m)
-08	1/2"	5/16"-18	24	M8	24	-08	1/2"	5/16"-18	24	M8	24
-12	3/4"	3/8"-16	43	M10	50	-12	3/4"	3/8"-16	43	M10	50
-16	1"	3/8"-16	43	M10	50	-16	1"	7/16"-14	70	M12	92
-20	1.1/4"	7/16"-14	70	M10	50	-20	1.1/4"	1/2"-13	105	M14	130
-24	1.1/2"	1/2"-13	105	M12	92	-24	1.1/2"	5/8"-11	210	M16	210
-32	2"	1/2"-13	105	M12	92	-32	2"	3/4"-10	360	M20	400

- a 公制螺纹油口标记。 Metric Thread Port Mark
- b 油口表面粗糙度 Ra3.2。 Port Roughness Ra3.2
- c 法兰衬垫最小宽度。 Flange Washer Min. Width.
- d 建议法兰衬垫宽度。 Recommended Flange Washer Width.

ISO 6162-1 法兰油口尺寸 ISO6162-1 Flange Port Dimensions (3.5MPa-35MPa) mm

法兰尺寸 Flange Size	d2	l2 min.	l6		l7 ± 0.25	l8 ± 0.25	l9 ± 0.8	l10 min.	l11 ± 0.25	l12 ± 0.25	l15 min.	l16 min.	l17 min.	R1 ± 0.4	r2 ± 0.8	
			max.	min.												
-8	1/2"	M8	14	54.9	53.1	38.1	19.05	46	33	17.5	8.75	56	52	49	8	23
-12	3/4"	M10	18	65.8	64.3	47.6	23.8	52	41	22.3	11.15	68	61	55	9	26
-16	1"	M10	18	70.6	69.1	52.4	26.2	29	48	26.2	13.1	72	67	61	9	29
-20	1.1/4"	M10	22	80.3	78.5	58.7	29.35	73	54	30.2	15.1	82	78	75	10	37
-24	1.1/2"	M12	22	94.5	93.0	69.9	34.95	83	64	35.7	17.85	96	90	85	12	41
-32	2"	M12	22	103.1	100.1	77.8	38.9	97	76	42.9	21.45	104	102	99	12	49

ISO6162-2 法兰油口尺寸 ISO6162-2 Flange Port Dimensions (35MPa-40MPa) mm

法兰规格 Flange Size	d2	l2 min.	l6		l7 ± 0.25	l8 ± 0.25	l9 ± 0.8	l10 min.	l11 ± 0.25	l12 ± 0.25	l15 min.	l16 min.	l17 min.	R1 ± 0.4	r2 ± 0.8	
			max.	min.												
-8	1/2"	M8	16	57.2	55.6	40.5	20.25	48	38	18.2	9.1	59	56	53	8	24
-12	3/4"	M10	18	72.1	70.6	50.8	25.4	60	48	23.8	11.9	75	70	66	10	30
-16	1"	M12	23	81.8	80.3	57.2	28.6	70	54	27.8	13.9	99	80	75	12	35
-20	1.1/4"	M12	20	96.0	94.5	66.7	33.35	78	60	31.8	15.9	116	90	83	14	39
-24	1.1/2"	M16	27	114.3	111.3	79.4	39.7	95	70	36.5	18.25	137	108	101	17	48
-32	2"	M20	35	134.9	134.9	96.8	48.4	114	86	44.5	22.25	164	128	120	18	57